

Giant Resonances – Wavelets, Scales and Level Densities

- Giant resonances
- Damping mechanisms, time and energy scales
- Fine structure
- Wavelets and characteristic scales
- Application: GQR
- Many-body nuclear models and damping mechanisms
- Relevance of scales: GTR
- Level densities of $J^\pi = 1^+, 2^+, 2^-$ states

Supported by DFG under SFB 634, 446 JAP 113 / 267 / 0-1 und 445 SUA-113 / 6 / 0-1

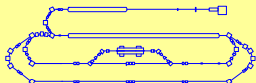

Key References for 2nd Lecture

- A. Shevchenko et al., Phys. Rev. Lett. **93**, 122501 (2004)
- Y. Kalmykov et al., Phys. Rev. Lett. **96**, 012502 (2006)
- Y. Kalmykov, C. Özen, K. Langanke, G. Martínez-Pinedo, P. von Neumann-Cosel and A. Richter, Phys. Rev. Lett. **99**, 202502 (2007)
- A. Shevchenko et al., Phys. Rev. C **77**, 024302 (2008)
- A. Shevchenko et al., Phys. Rev. C **79**, 044305 (2009)
- I. Petermann, K. Langanke, G. Martinez-Pinedo, P. von Neumann-Cosel, F. Nowacki and A. Richter, Phys. Rev. C **81**, 014308 (2010)

Giant Resonances

Monopole
 $\Delta L = 0$

Gamow-Teller

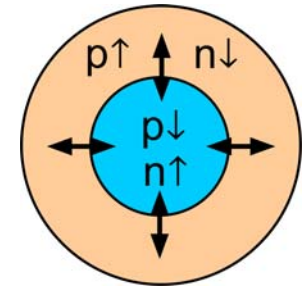

Dipole
 $\Delta L = 1$

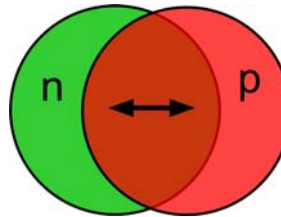

Quadrupole
 $\Delta L = 2$

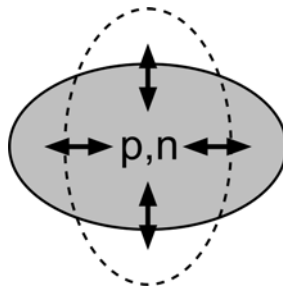

$\Delta T = 0$
 $\Delta S = 0$

$\Delta T = 1$
 $\Delta S = 0$

$\Delta T = 0$
 $\Delta S = 1$

$\Delta T = 1$
 $\Delta S = 1$

Giant Resonances

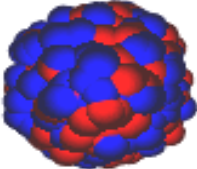
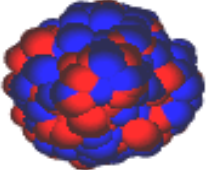
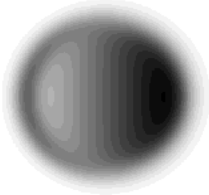
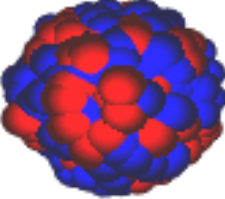
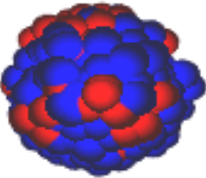
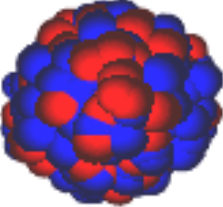
	Isoscalar	Isovector
Monopole $\Delta L = 0$		
Dipole $\Delta L = 1$		
Quadrupole $\Delta L = 2$		
	$\Delta T = 0$ $\Delta S = 0$	$\Delta T = 1$ $\Delta S = 0$

→ interplay between collective and s.p. motion

Courtesy of P. Adrich

Isoscalar Quadrupole Mode

- Pitthan and Walcher (Darmstadt, 1972)

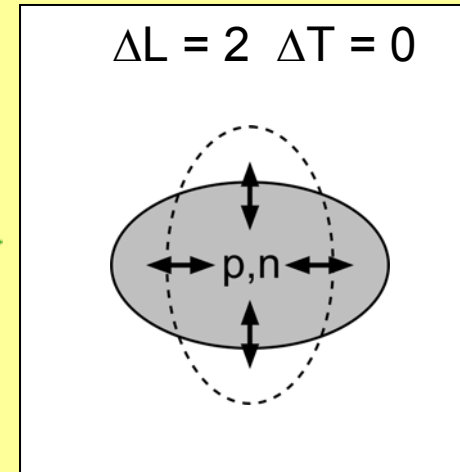

- Centroid energy: $E_x \sim 63 A^{-1/3}$ MeV
- Width
- Damping mechanisms

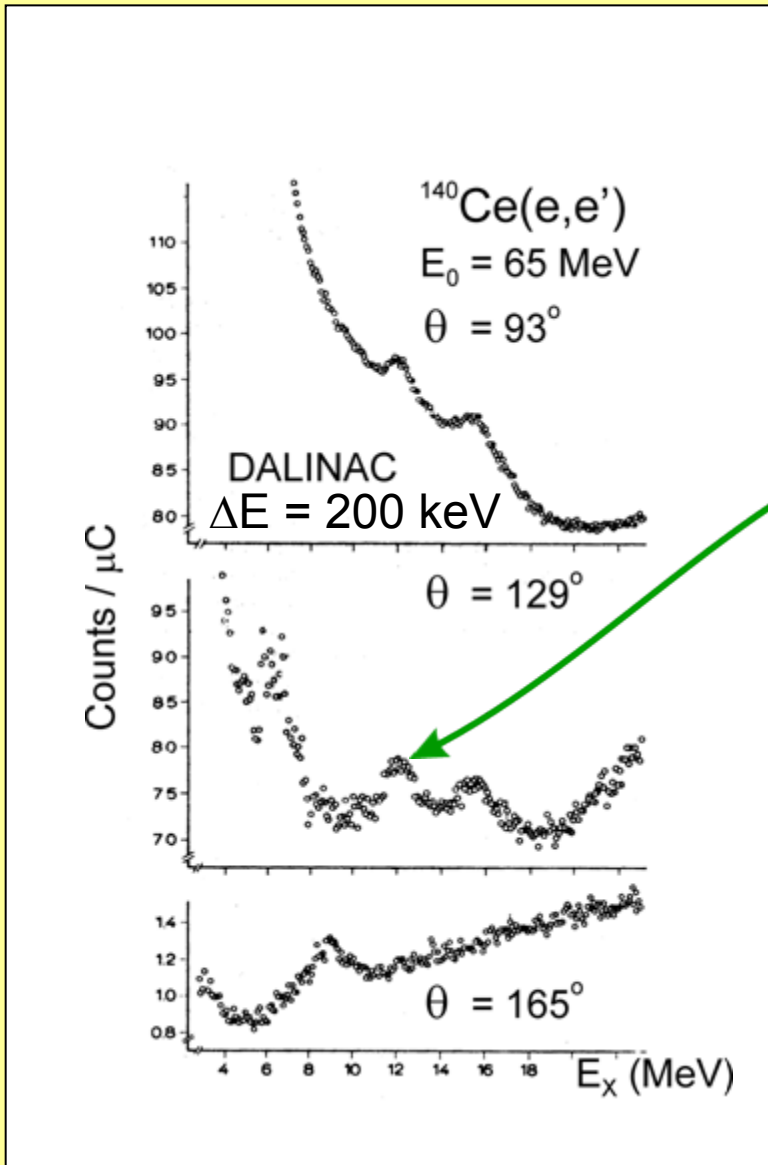

Early Work on GR's: ^{90}Zr

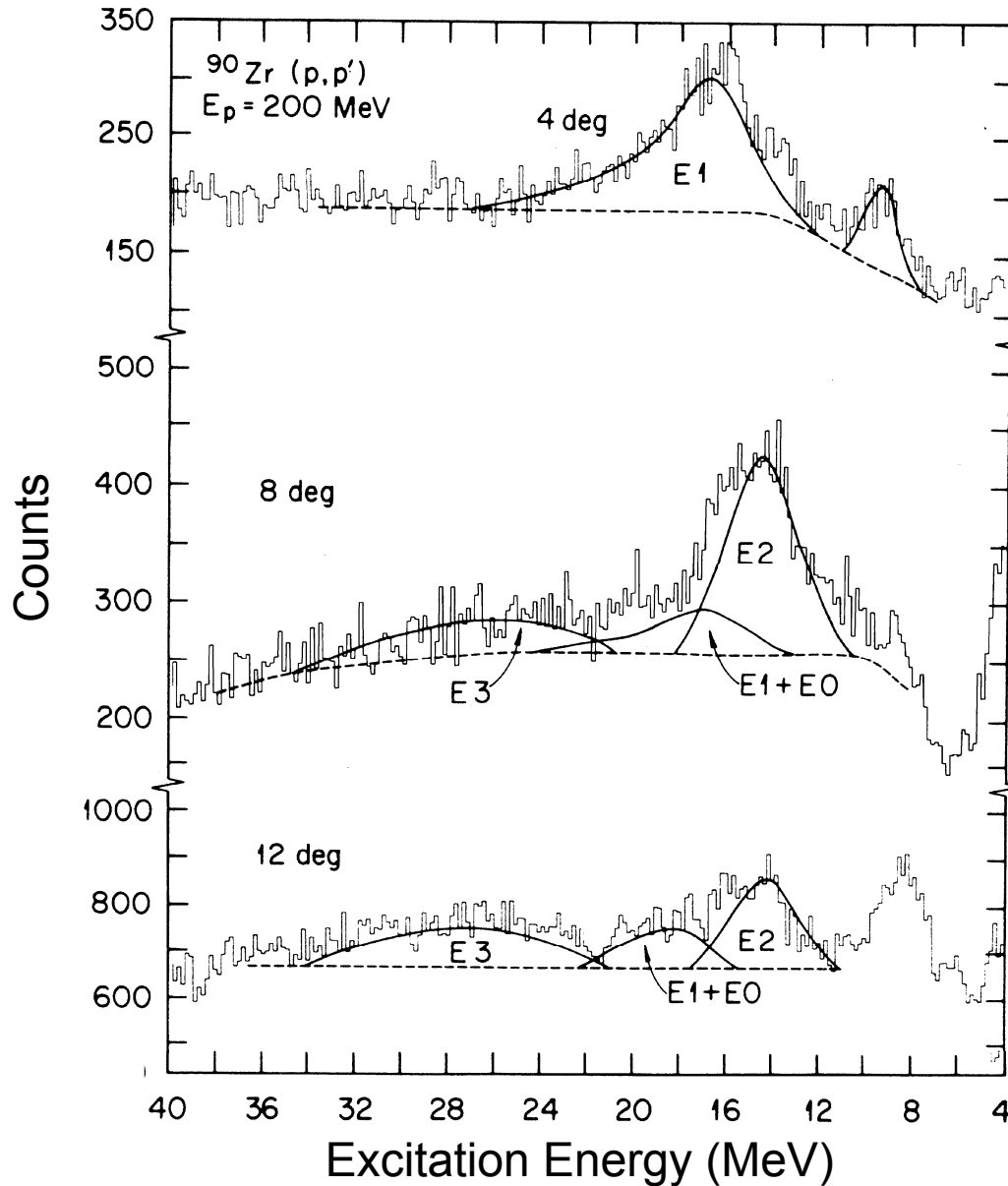

Bertrand et al.
(1981)

ΔE (FWHM) ~ 1 MeV

Microscopic Picture of Giant Resonances: ^{90}Zr

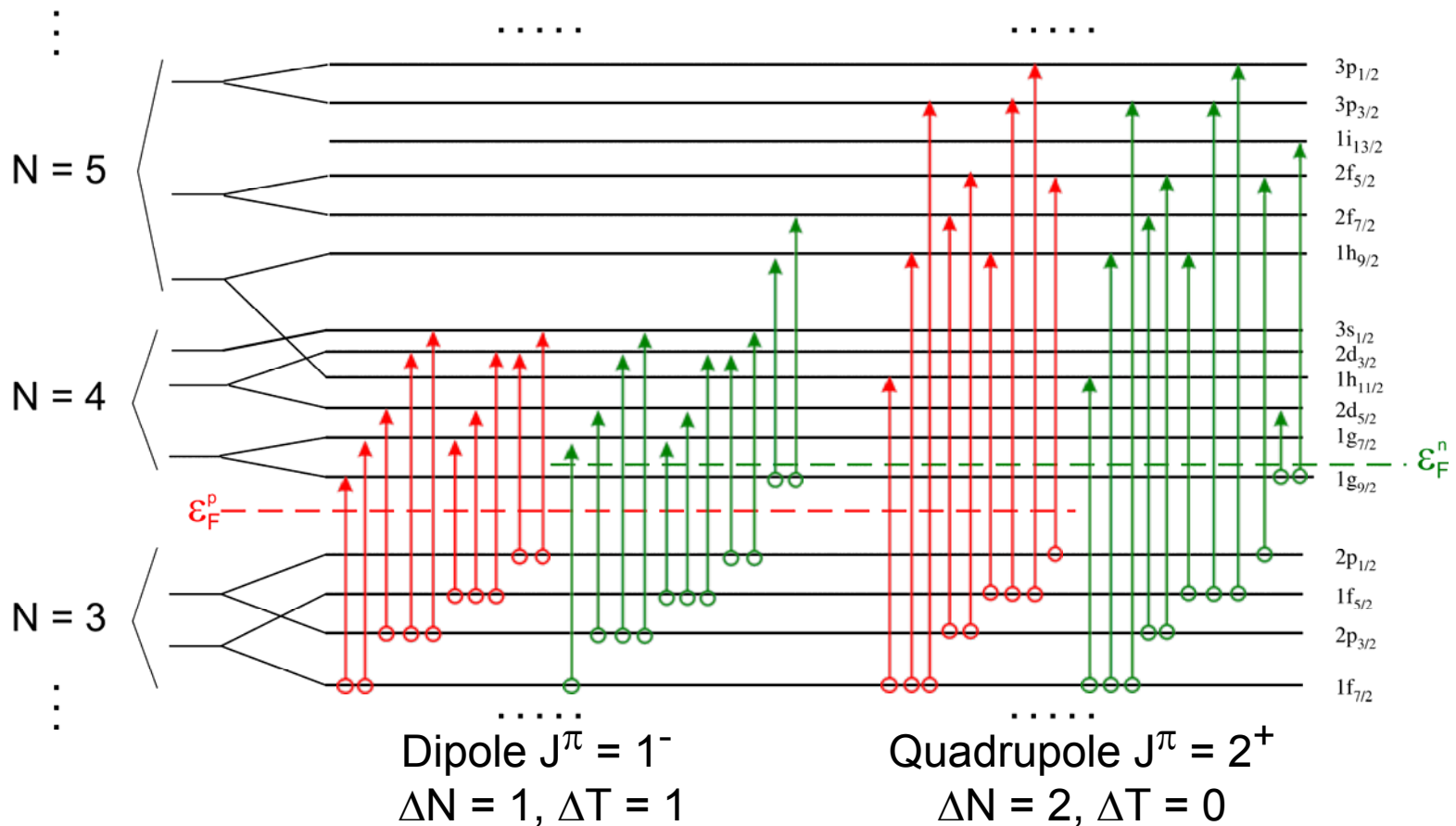

Giant vibration $\hat{=}$ coherent superposition of elementary p-h excitations

$$\Psi^{J^\pi} = \sum_{\alpha} c_{\alpha} | (p-h)_{\alpha}^{J^\pi} \rangle \quad H(1, \dots, A) = \underbrace{H_0(1, \dots, A)}_{IPM} + \underbrace{\sum_{i,k} V(i, k)}_{?}$$

Excitation and Decay of Giant Resonances

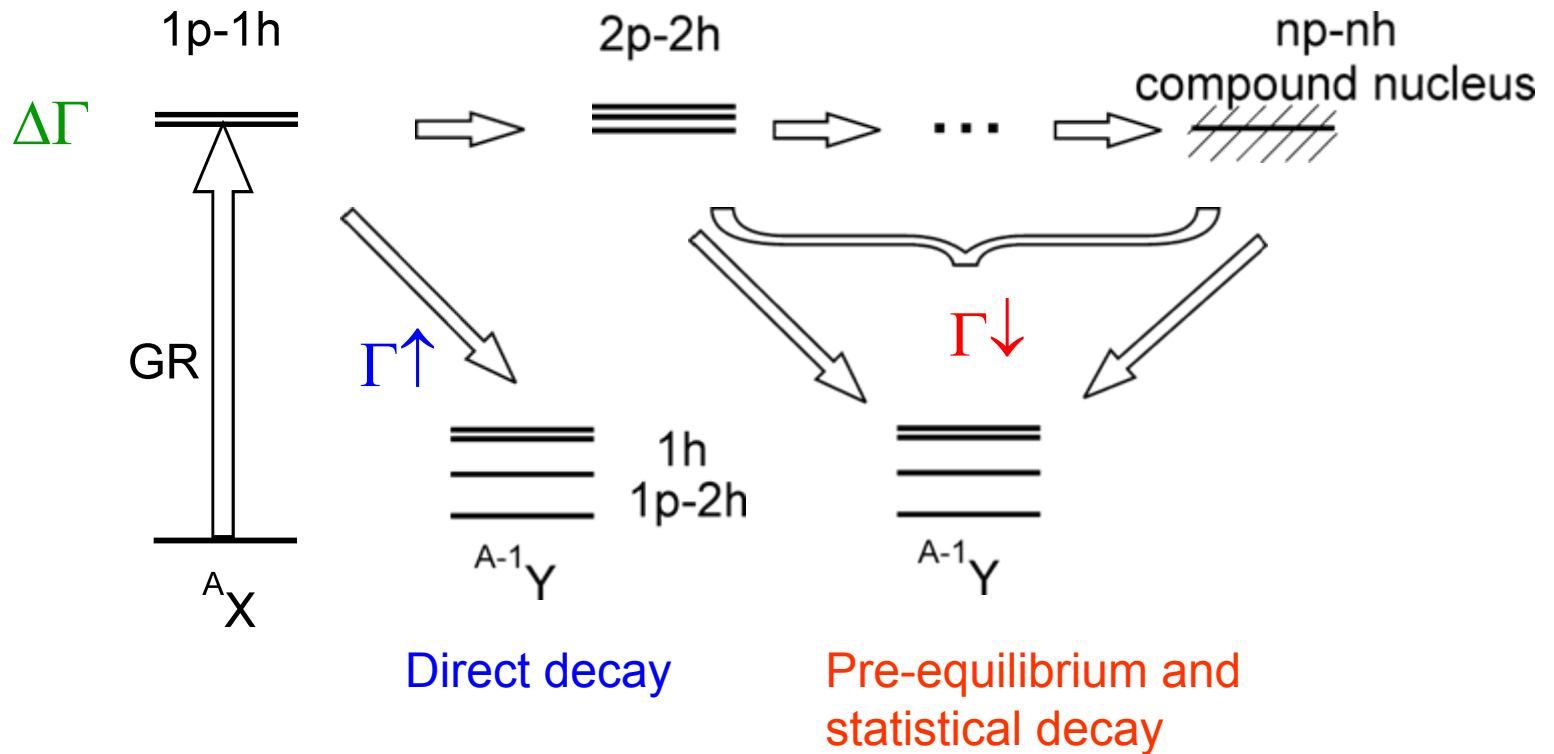

$$\Gamma = \Delta\Gamma + \Gamma\uparrow + \Gamma\downarrow$$

Resonance
width

Landau
damping

Escape
width

Spreading
width

Doorway State Model

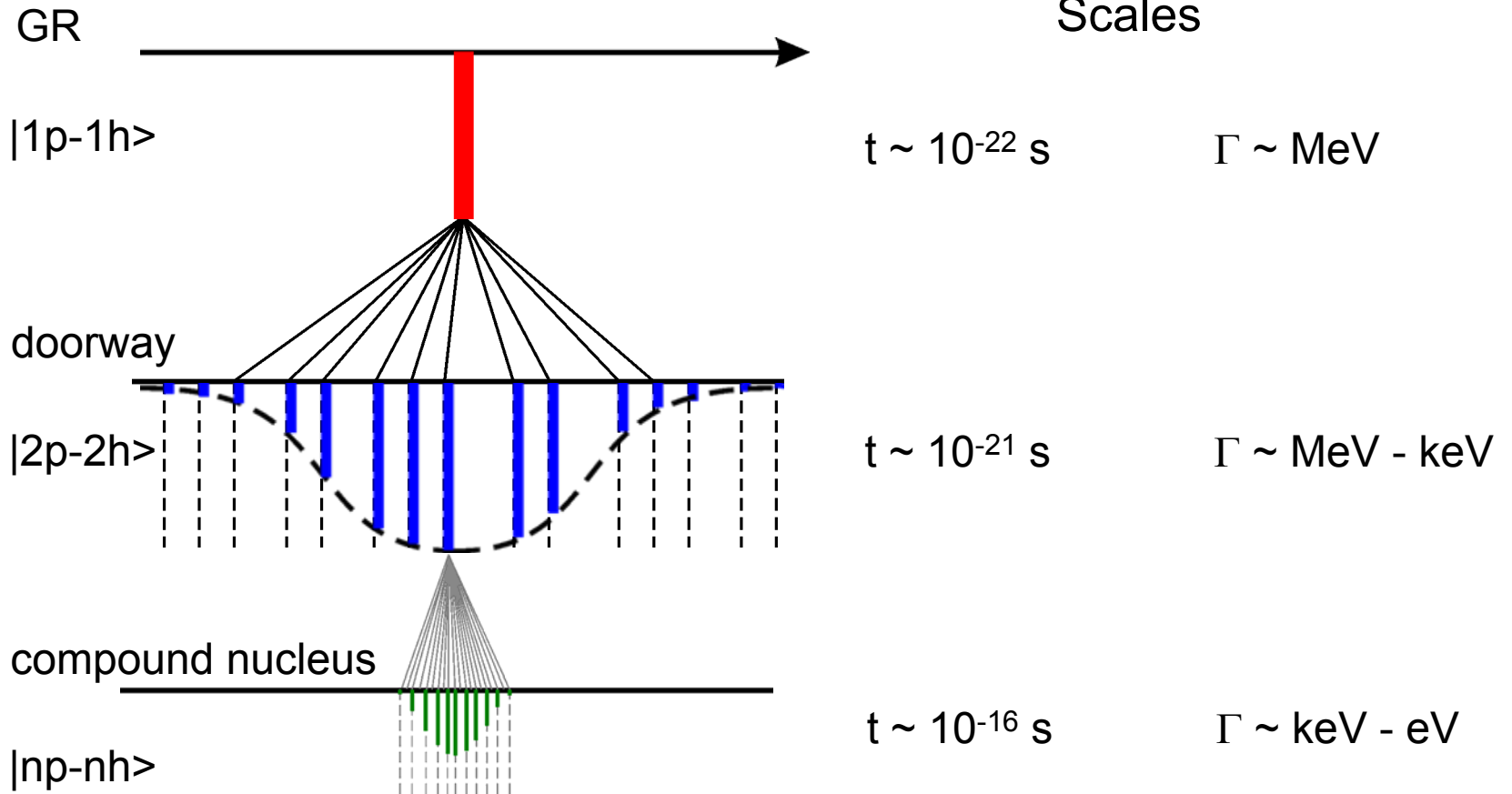

Fine Structure of Giant Resonances

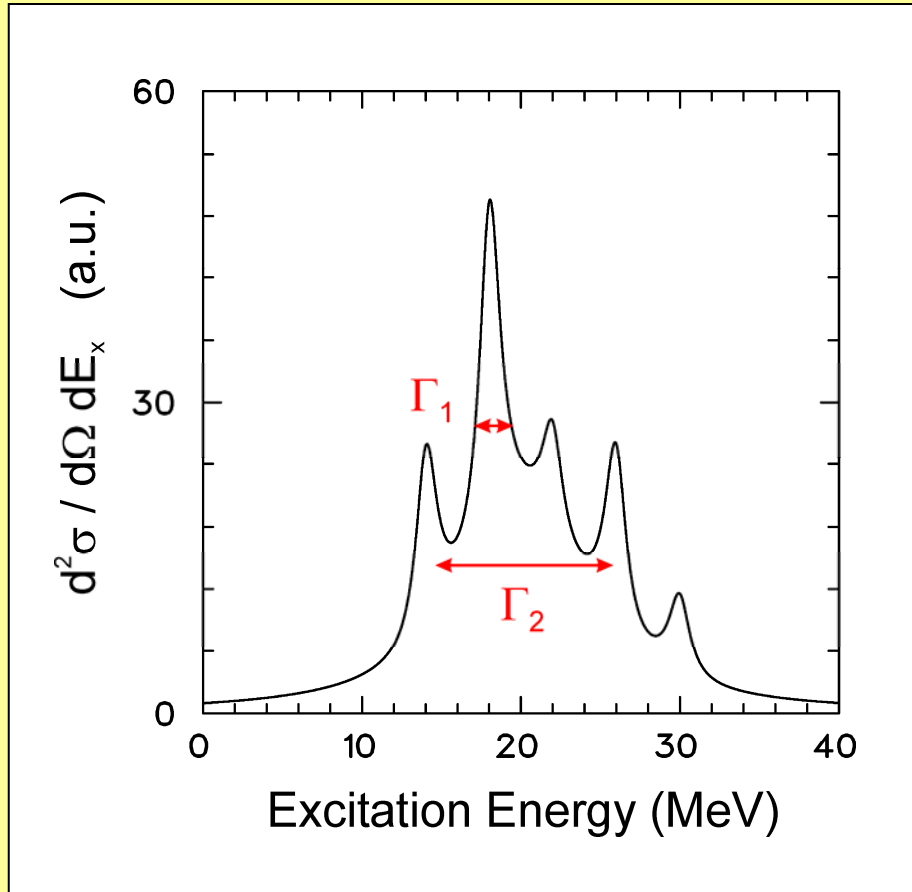

- High resolution is crucial
- Possible probes: electrons and hadrons

Fine Structure of Giant Resonances

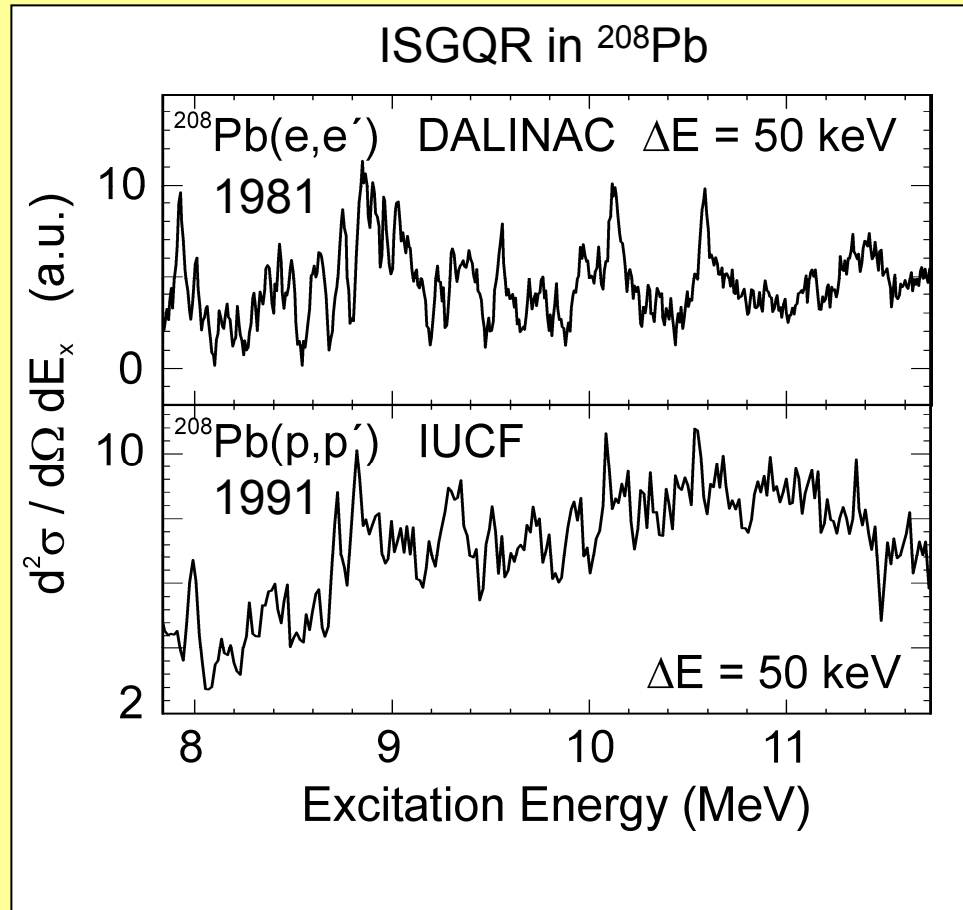

● Different probes but similar structures

→ physical information content is the same

Fine Structure of Giant Resonances

- Global phenomenon?
 - Other nuclei
 - Other resonances
- Methods for characterization of fine structure
- Goal: dominant damping mechanisms

Recent Experiments

Place:

iThemba LABS,
South Africa

RCNP, Osaka

Reaction:

ISGQR from (p,p')

GT from (³He,t)

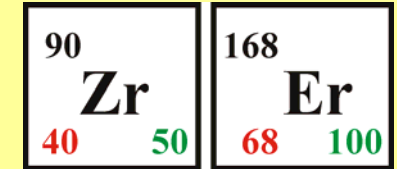
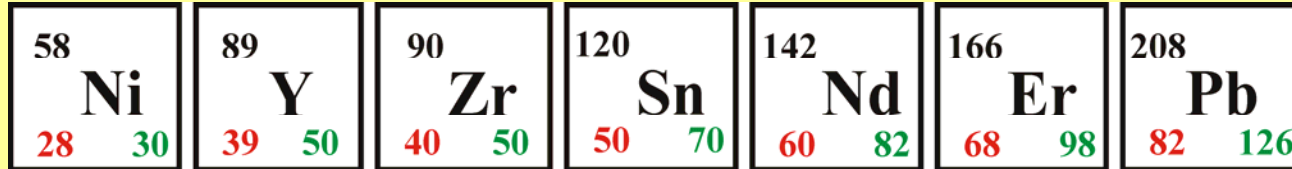

Beam energy:

200 MeV

140 MeV/u

Scattering angles:

8° – 10°
($\Delta L = 2$)

0°
($\Delta L = 0$)

Energy resolution:
(FWHM)

$\Delta E = 35 - 50$ keV

$\Delta E = 50$ keV

New data: ²⁷Al, ²⁸Si, ⁴⁰Ca presently analysed

Fine Structure of the ISGQR

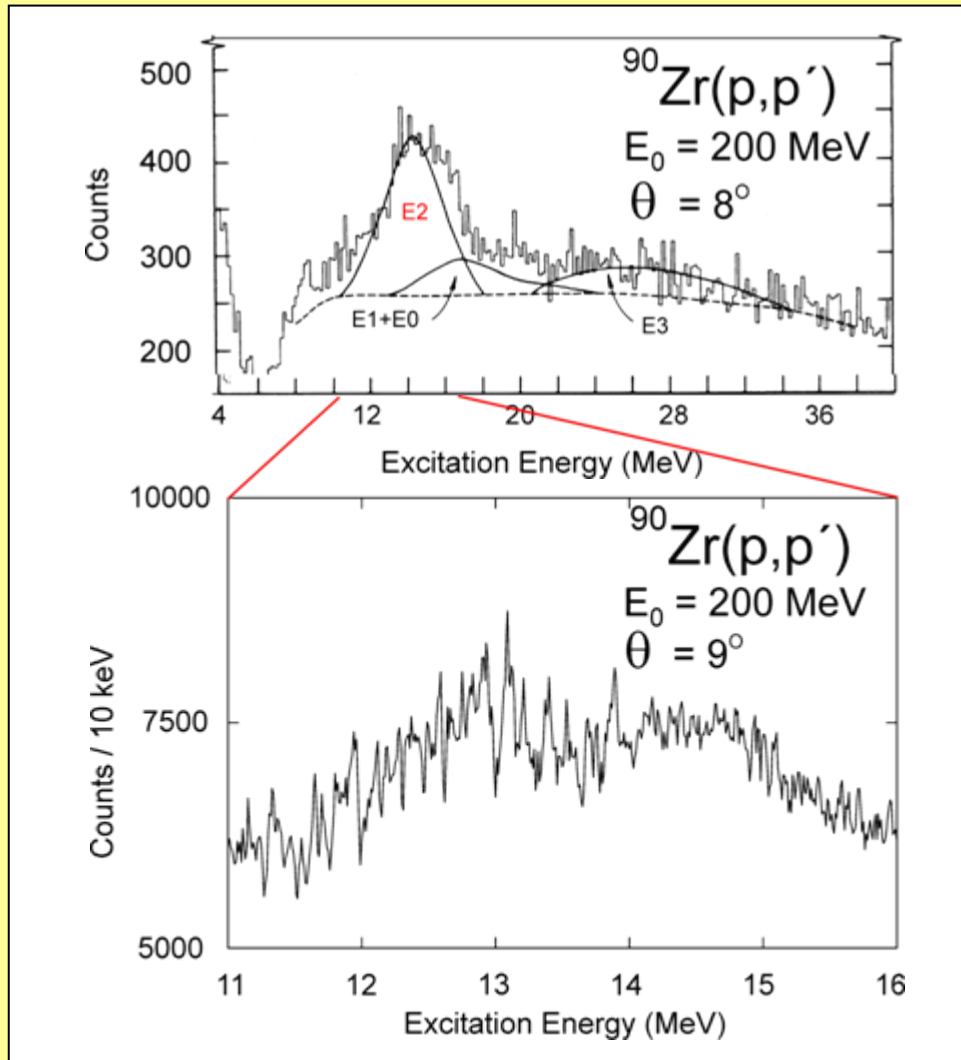

$\Delta E \approx 1$ MeV
TRIUMF (1981)

$\Delta E \approx 40$ keV
iThemba (2004)

- Fluctuations of different strengths and scales
- Not a Lorentzian

Fine Structure of the ISGQR in Other Nuclei

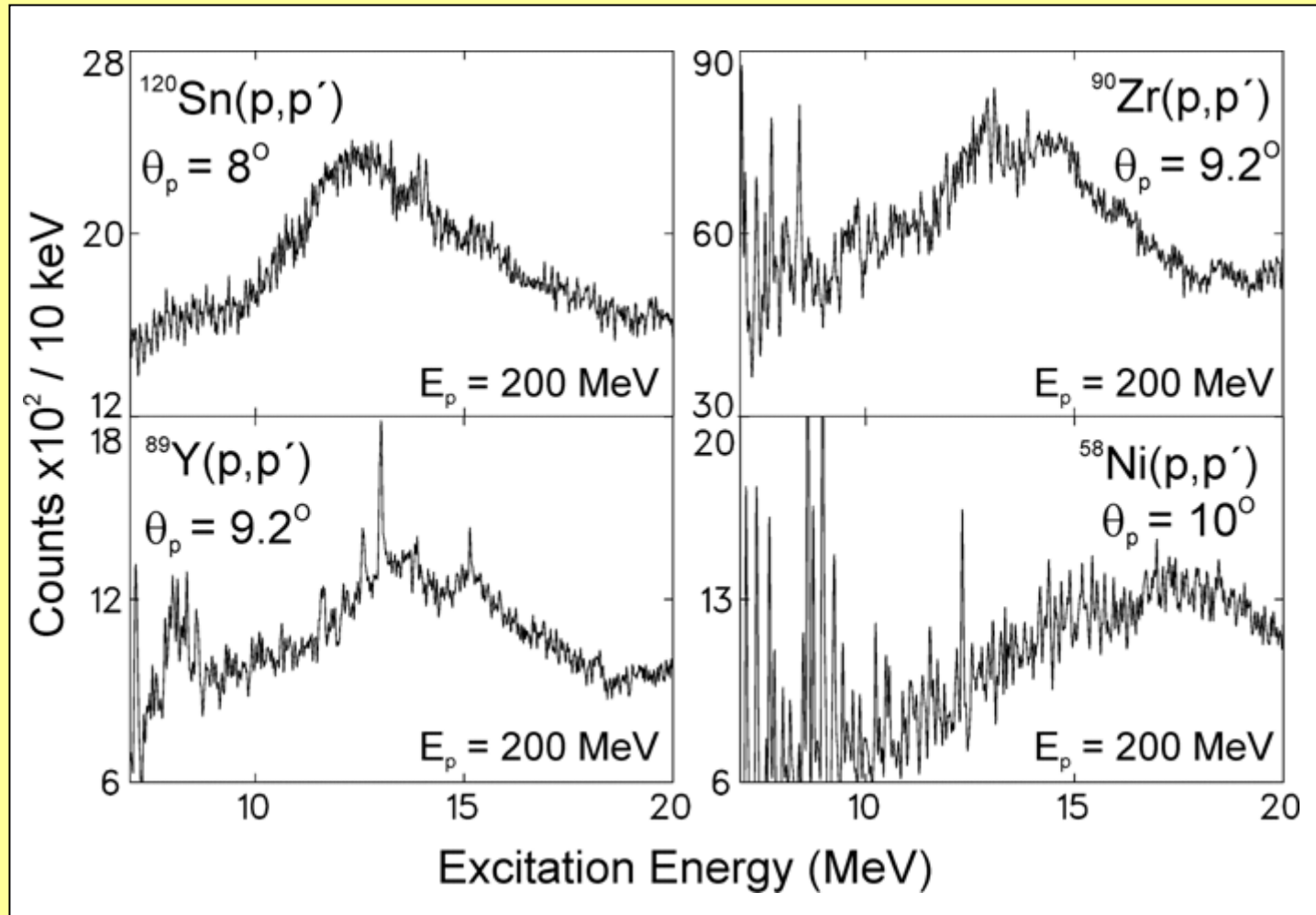

- Fine structure of the ISGQR is a global phenomenon

Fine Structure in Deformed Nuclei?

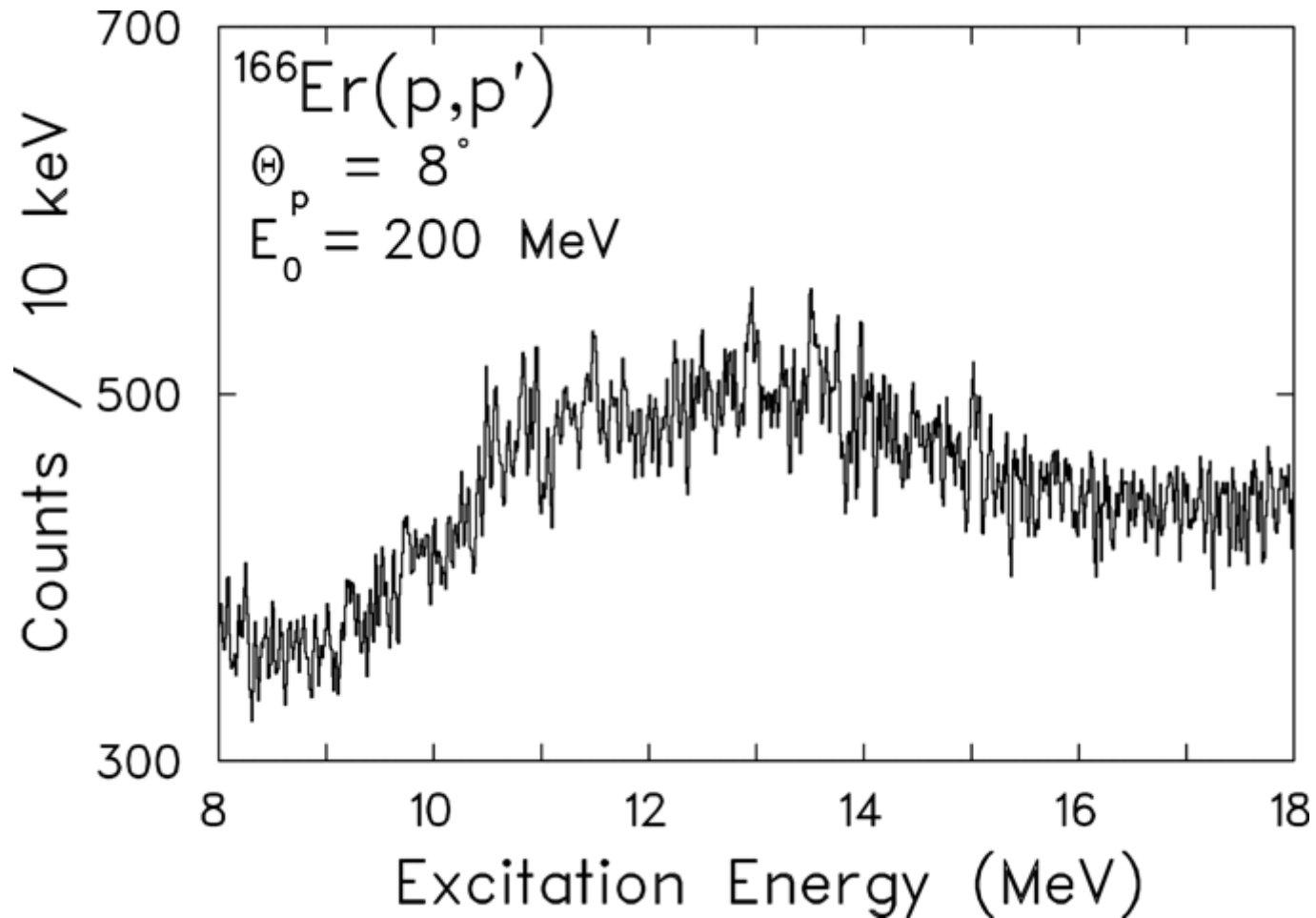

Wavelet Analysis

$$\int_{-\infty}^{\infty} \Psi^*(x) dx = 0 \quad \text{and} \quad \int_{-\infty}^{\infty} |\Psi^*(x)|^2 dx < \infty$$

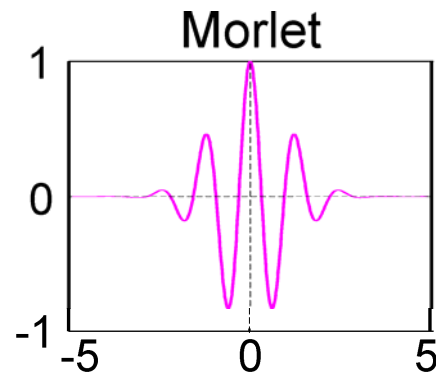

$$\Psi(x) = \cos(2\pi\omega x) e^{-x^2/2}$$

Wavelet coefficients:

$$C(\delta E, E_x) = \frac{1}{\sqrt{\delta E}} \int \sigma(E) \Psi^*\left(\frac{E_x - E}{\delta E}\right) dE$$

↑ ↑ ↑ ↑
scale position spectrum wavelet

Continuous: $\delta E, E_x$ are varied continuously

Wavelet Analysis

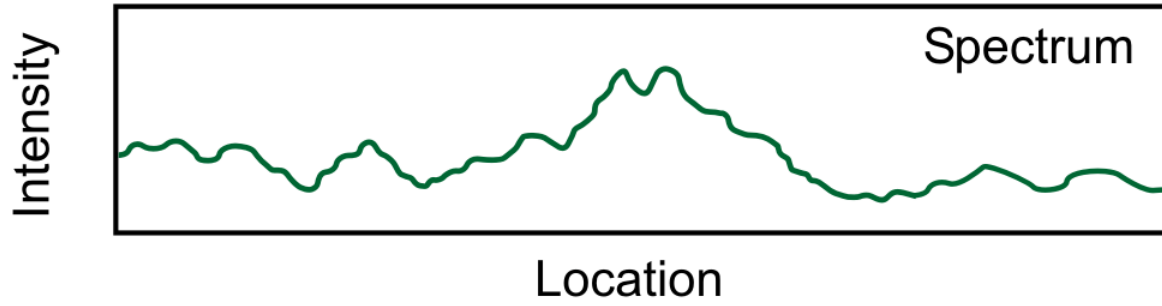
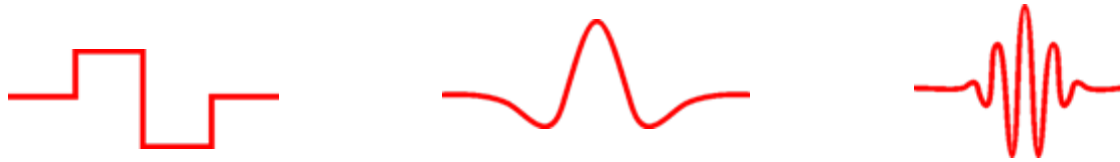

Wavelet Analysis

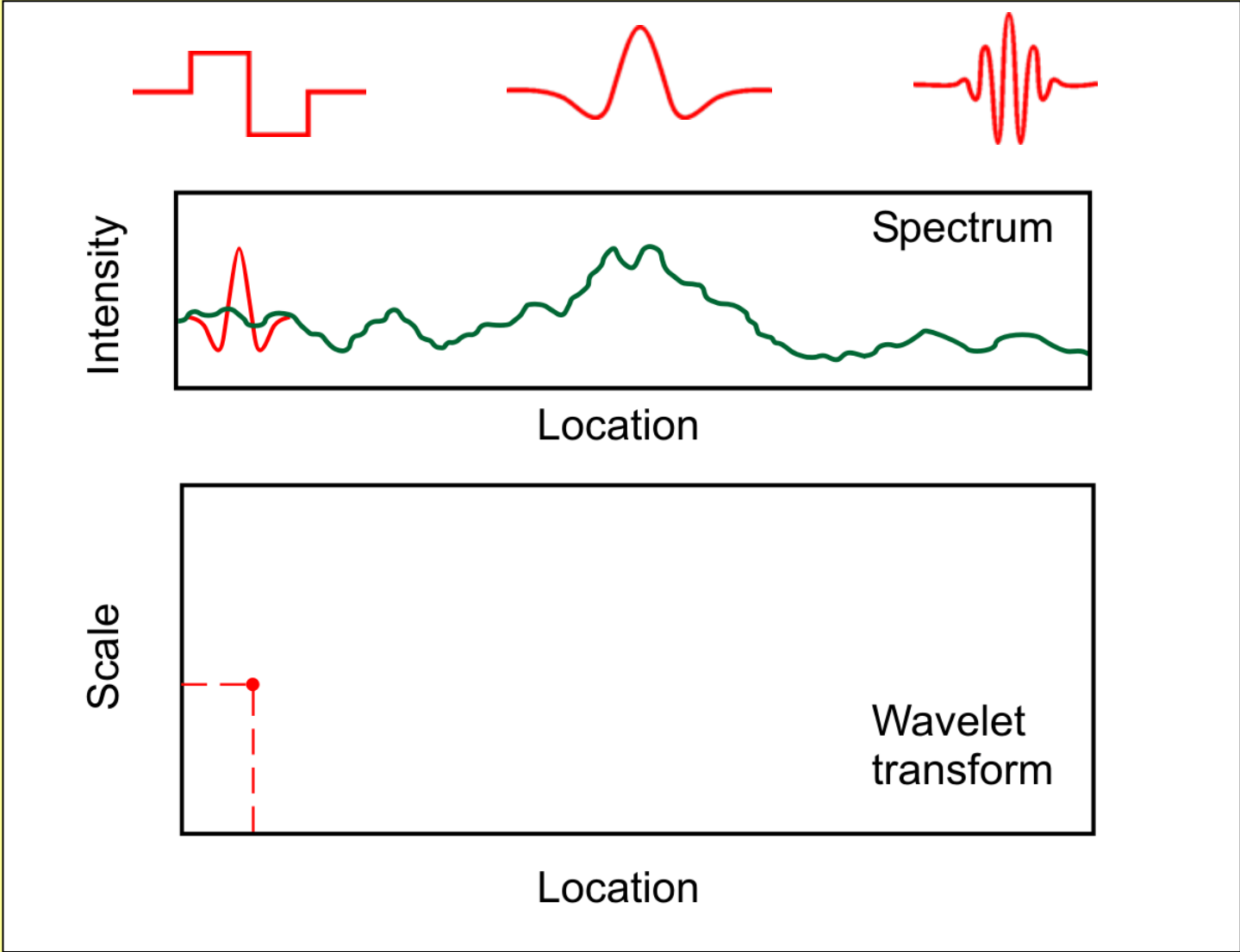

Wavelet Analysis

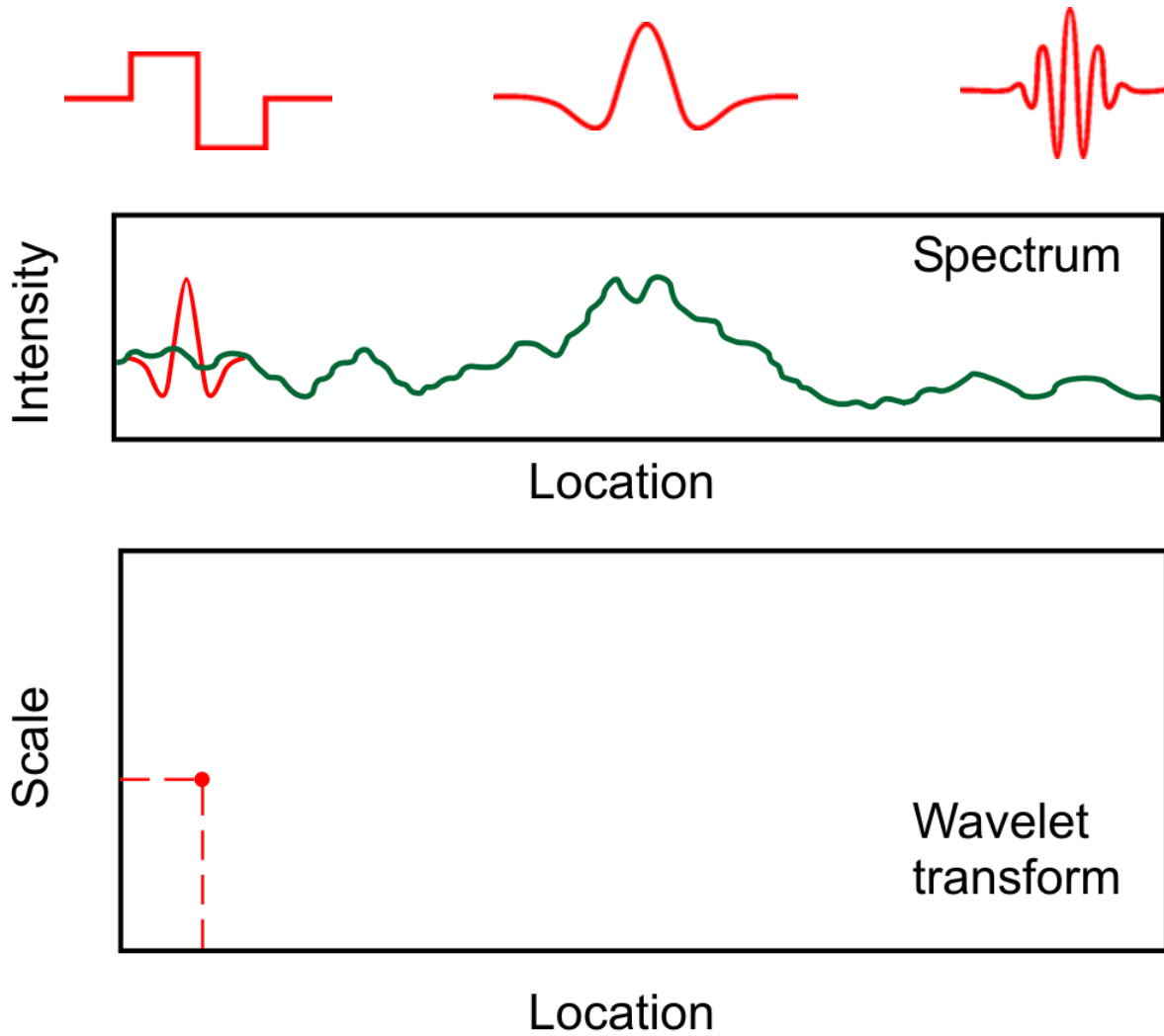

Wavelet Analysis

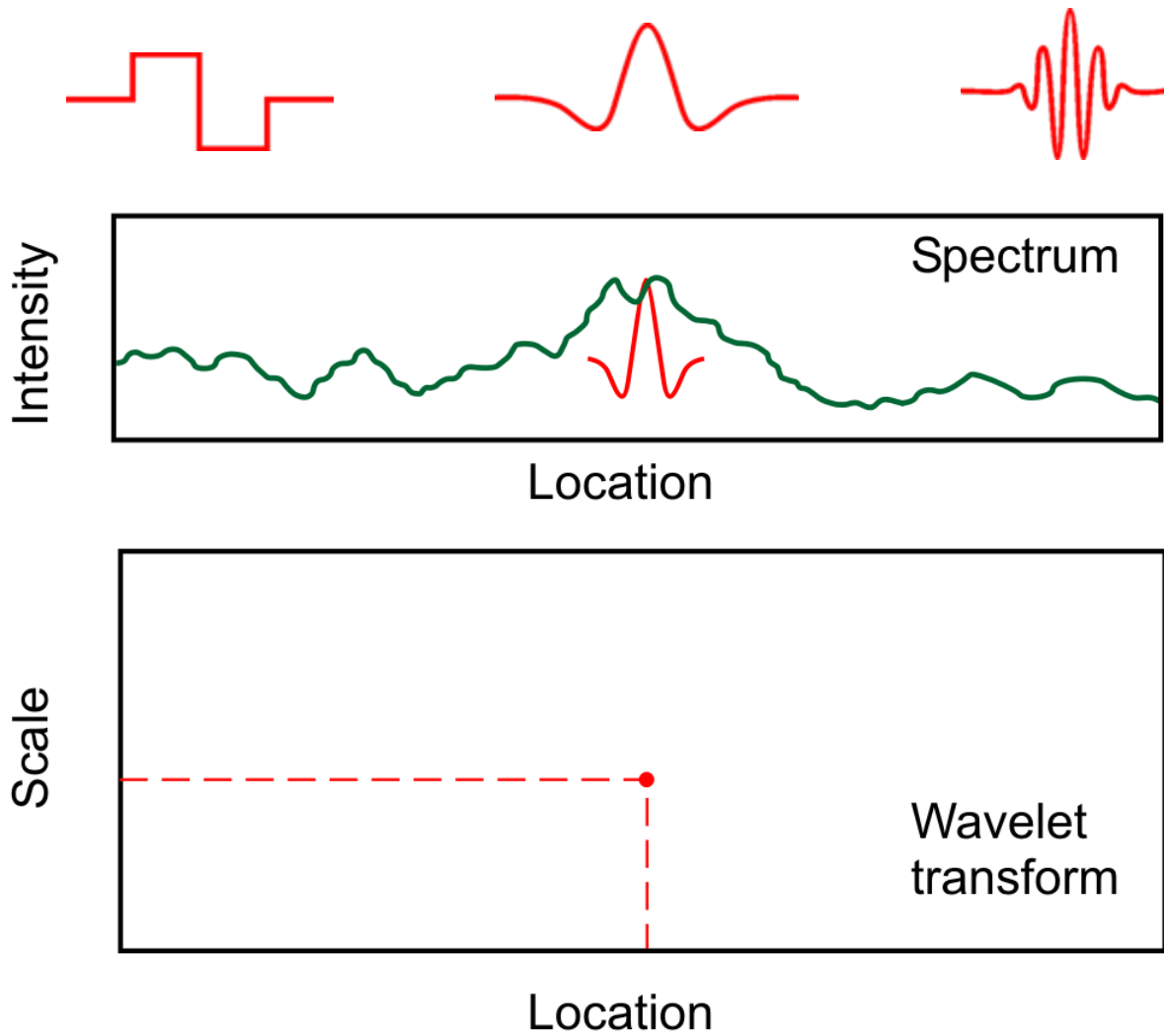

$^{208}\text{Pb}(p,p')$ at iThemba LABS

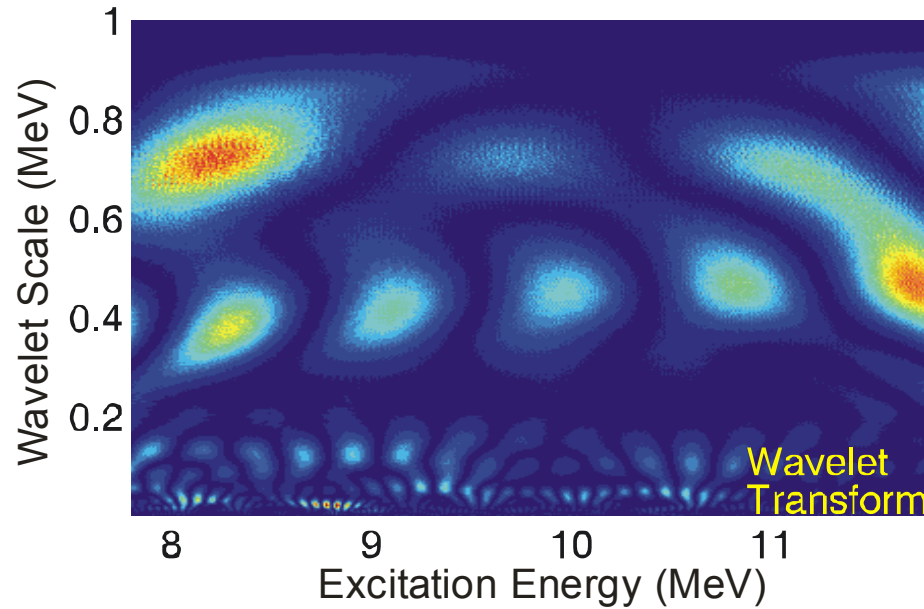
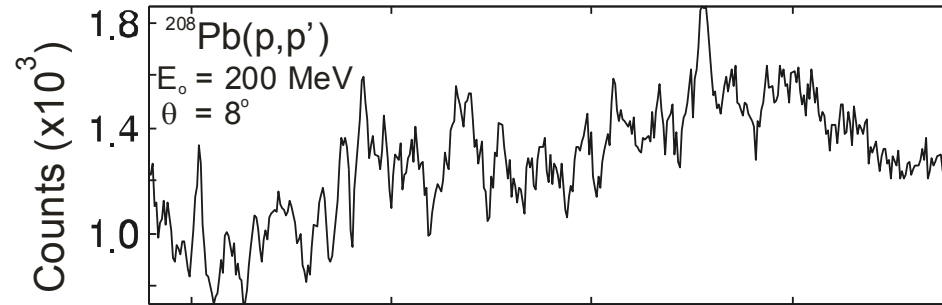
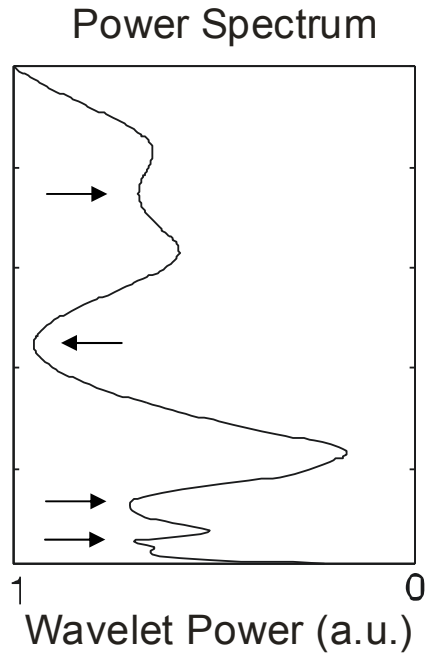

$^{208}\text{Pb}(e,e')$ at DALINAC

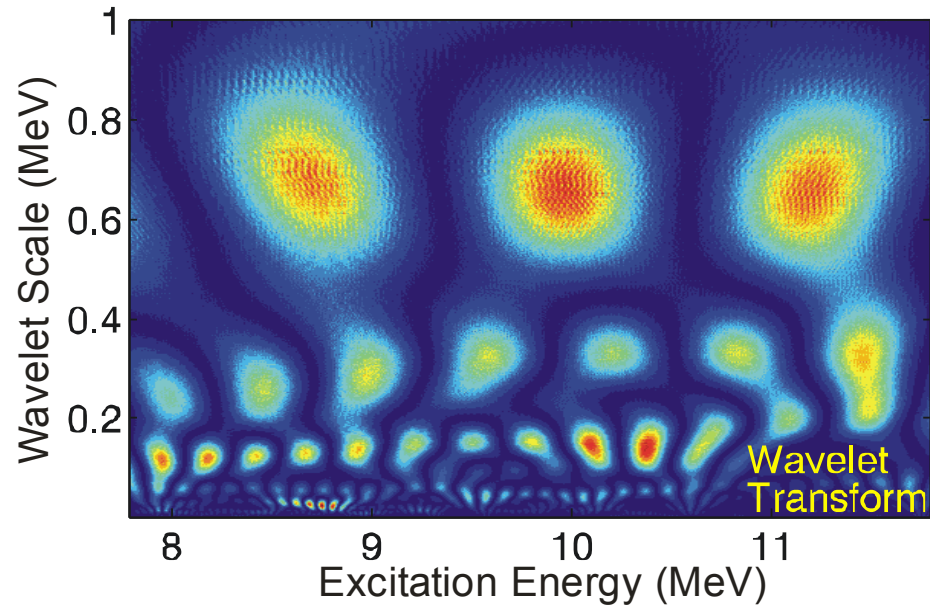
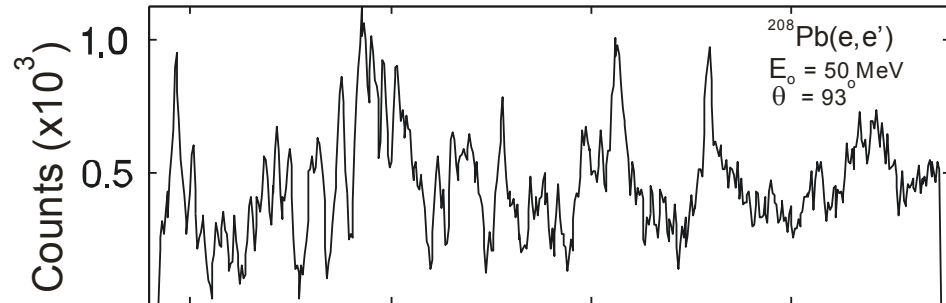
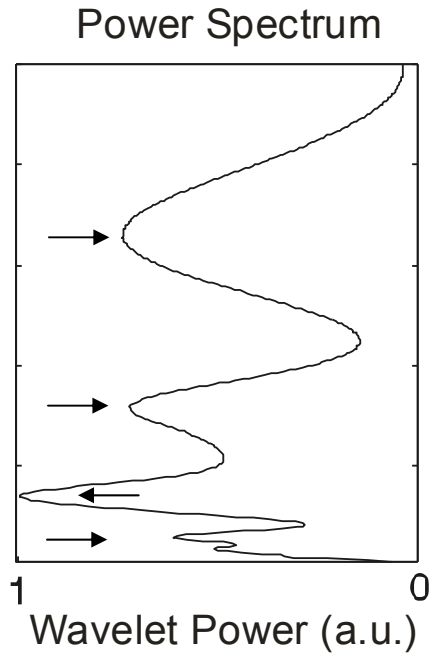

Summary of Scales

- Scales are found in all nuclei

- Three classes

I : ~ 100 keV

all nuclei

II : ~ 200 – 900 keV

changes with mass number

III : ~ 1.2 – 4.7 MeV

gross width

Interpretation of the Scales - Models

● RPA	Wambach et al.	(2000)	←
● SRPA	Wambach et al.	(2000)	←
● QPM	Ponomarev	(2003)	←
● ETDHF	Lacroix et al.	(1997)	
● 1p – 1h ⊗ phonon ETFFS	Kamerdziev et al.	(1997)	

^{208}Pb RPA

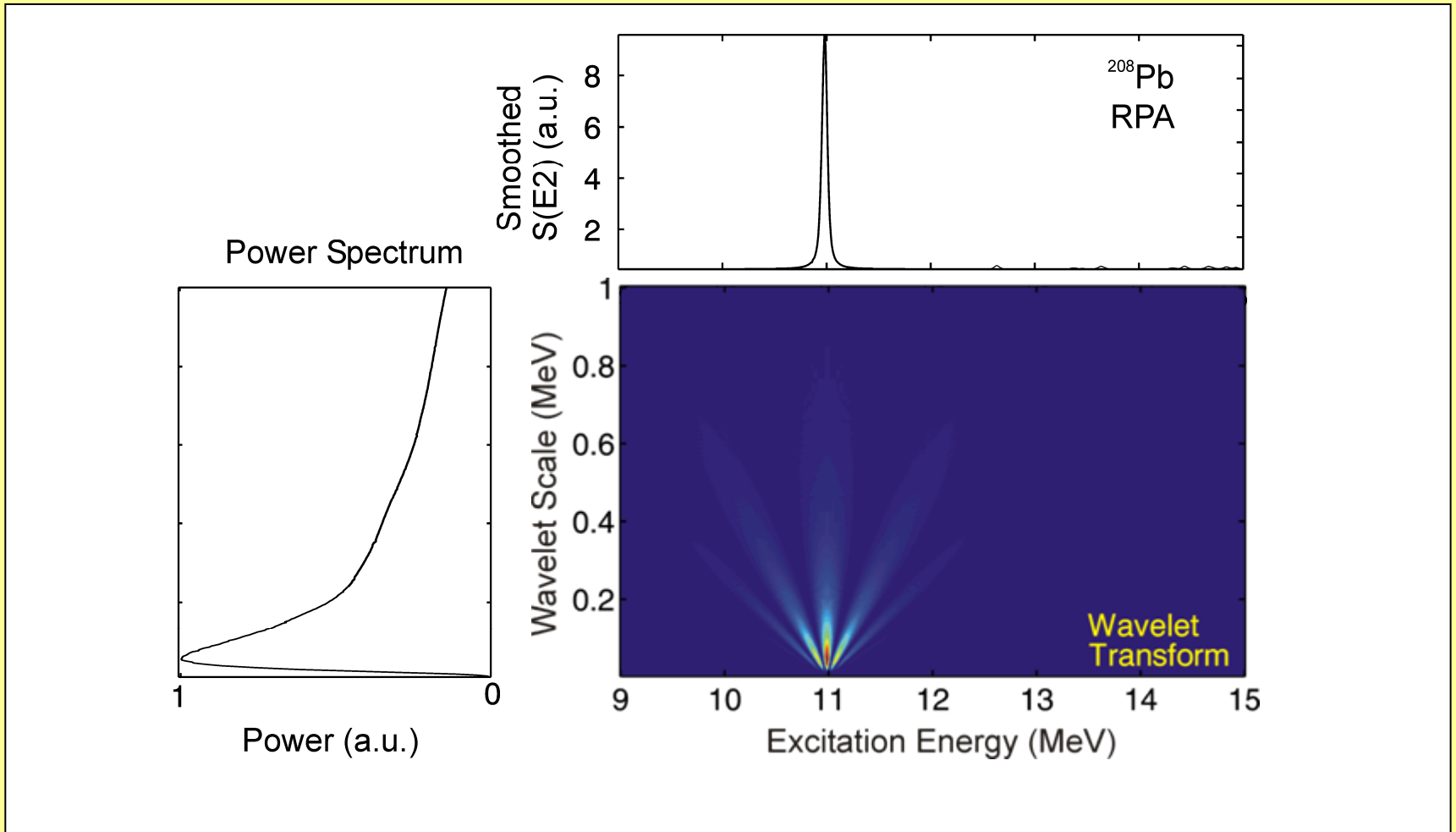

● No scales from 1p-1h states

^{208}Pb SRPA

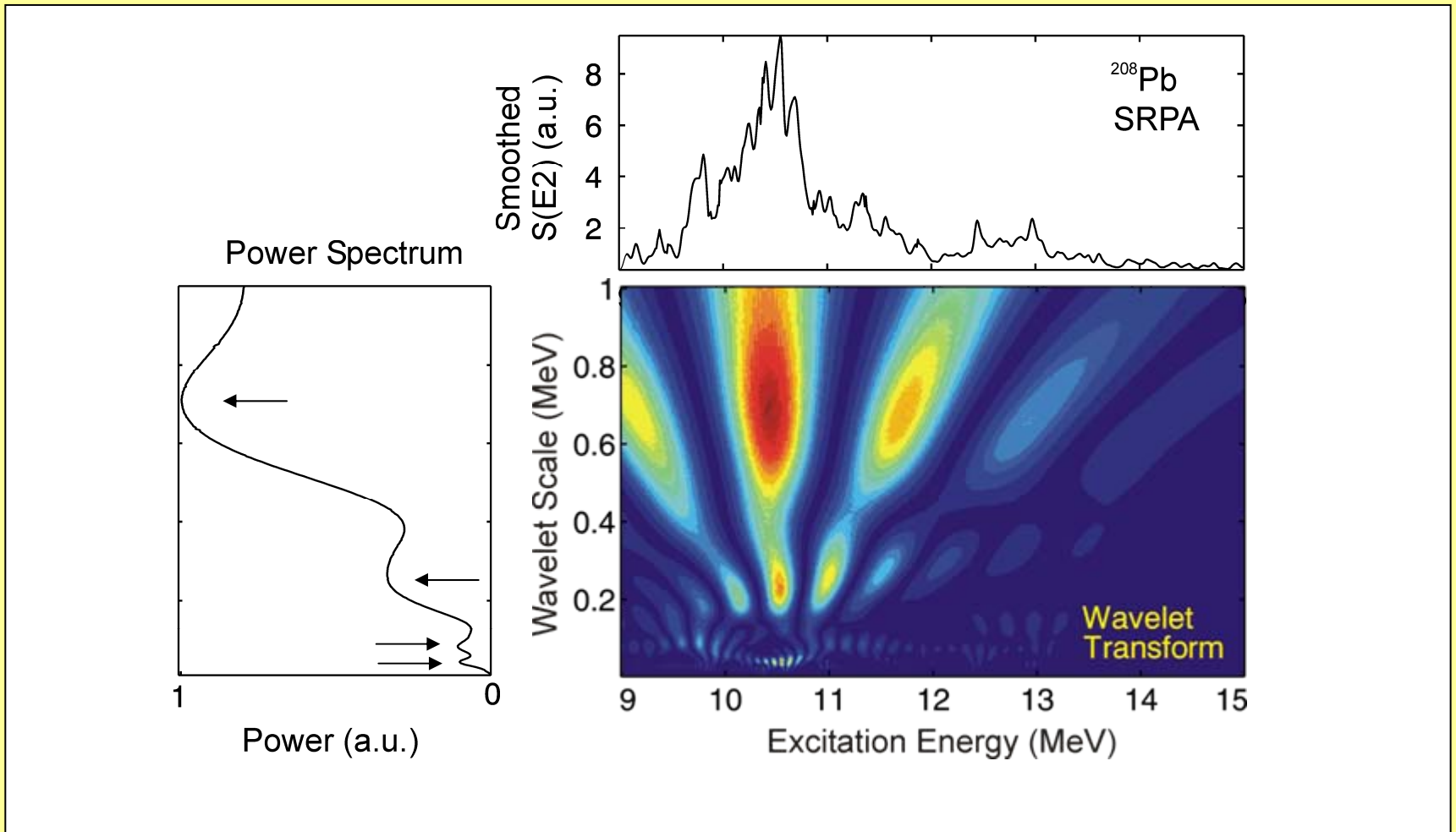

- Coupling to 2p-2h generates fine structure and scales

Microscopic Models: Case of ^{208}Pb

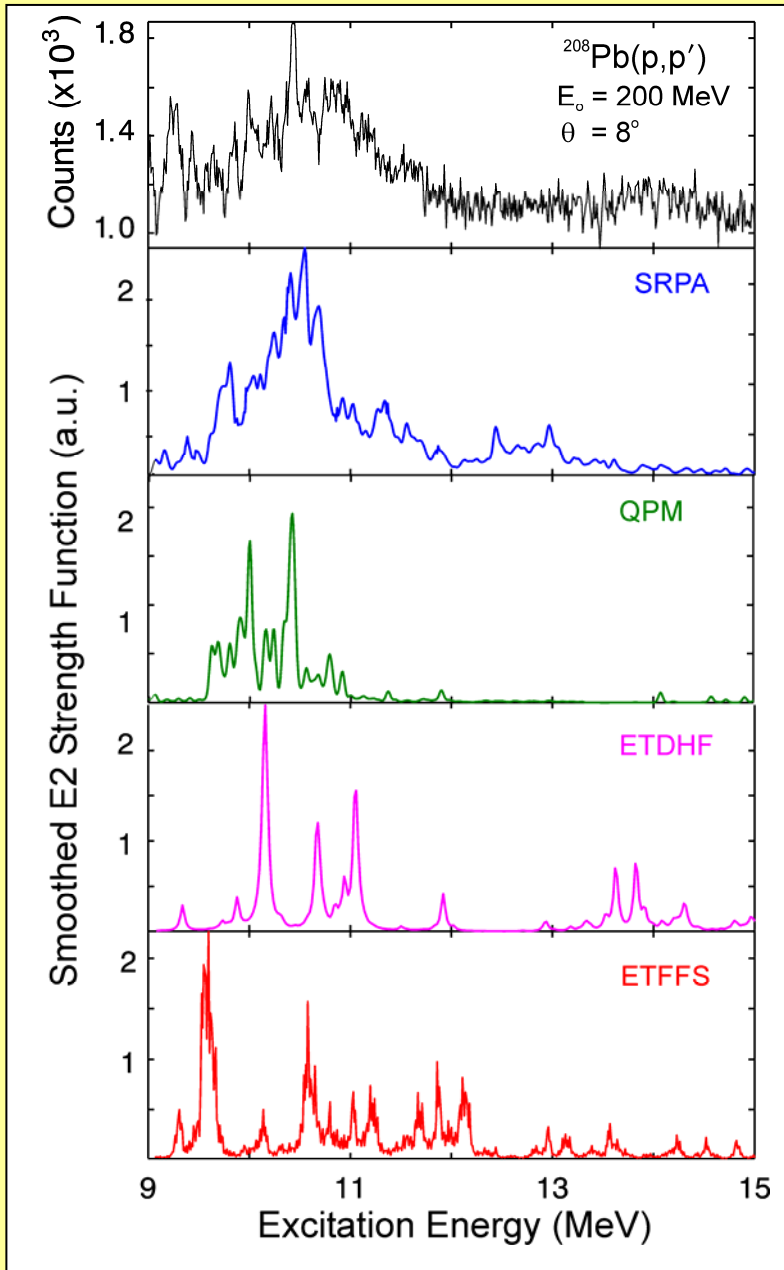

- Large differences between model predictions
- No a priori judgement possible which model should be preferred
- Use wavelet analysis for a quantitative measure in comparison with the experimental observations

Experiment vs. Model Predictions

	Scales (keV)		
	I	II	III
Exp / keV	110	550	1500 2600
Models / keV			
SRPA	80	250 800	2100
QPM	110	770	1400
ETDHF	120	230	1000
ETFFS	130	310 570	2500

- Three classes of scales as in the experiment on a qualitative level
- But strong variations of **class II** and **class III** scales
- Take QPM for semi-quantitative analysis of damping mechanisms

Semi-Quantitative Attempt of Interpretation: ^{208}Pb as Example

Two types of dissipation mechanisms:

collective damping



low-lying surface vibrations



$1p - 1h \otimes \text{phonon}$

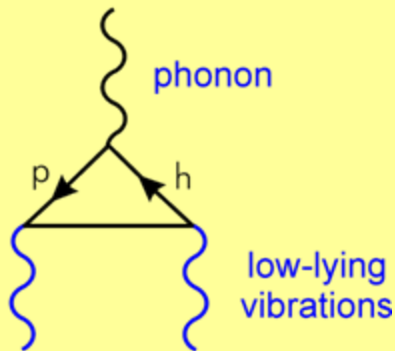

non-collective damping



background states



coupling to $2p - 2h$ states

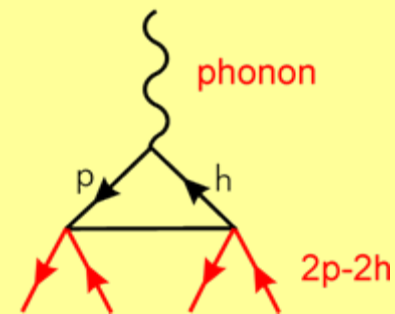

How Can the Two Mechanisms Be Separated: Distribution of the Coupling Matrix Elements

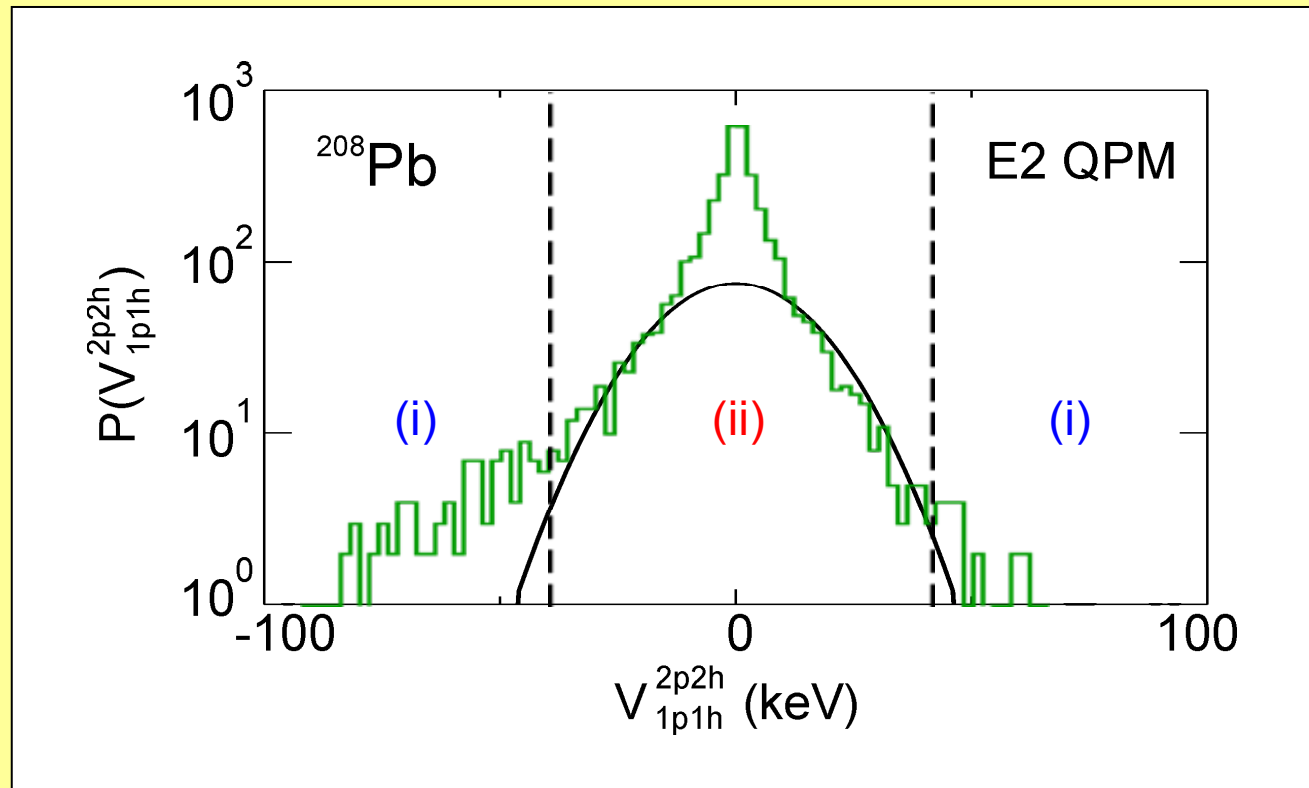

- QPM: distribution for $\langle 1p1h | V_{1p1h}^{2p2h} | 2p2h \rangle$
- RMT: deviations at large and at small m.e. → **4th Lecture**
- Large m.e. define the **collective damping** mechanism
- Small m.e. are responsible for the **non-collective** damping

Collective vs. Non-Collective Damping in ^{208}Pb

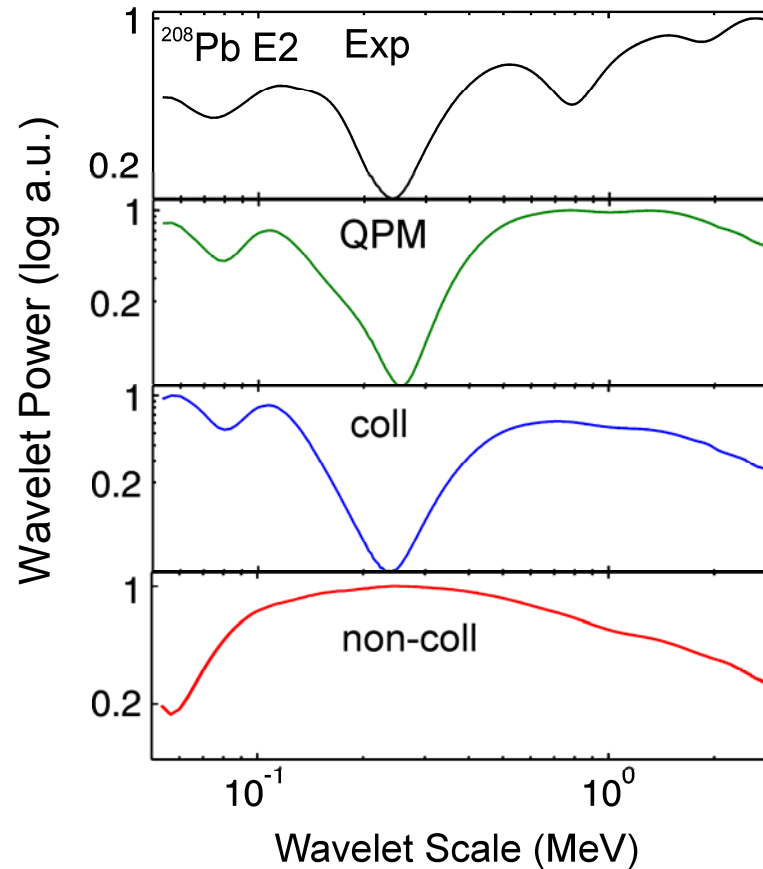

● Collective part:

all scales

● Non-collective part:

no prominent scales



Stochastic coupling

Spreading of a GR due to the Coupling to Doorway States and Decay into Compound Nucleus States

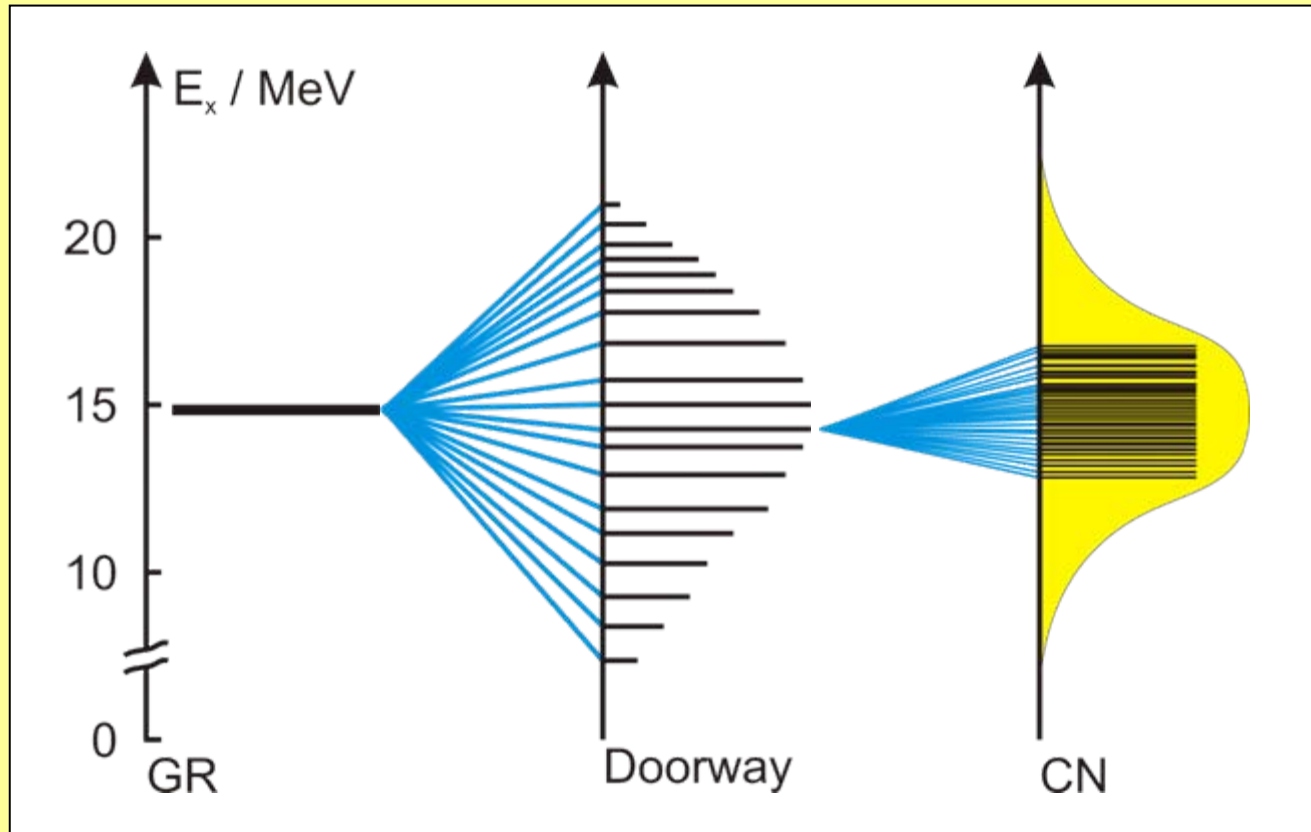

- First step of coupling hierarchy $1p-1h \rightarrow 2p-2h$ has been tested
- Further steps require improvement in resolution

IVGDR in Exclusive Electron Scattering

$^{40}\text{Ca}(e,e'p_0)^{39}\text{K}$

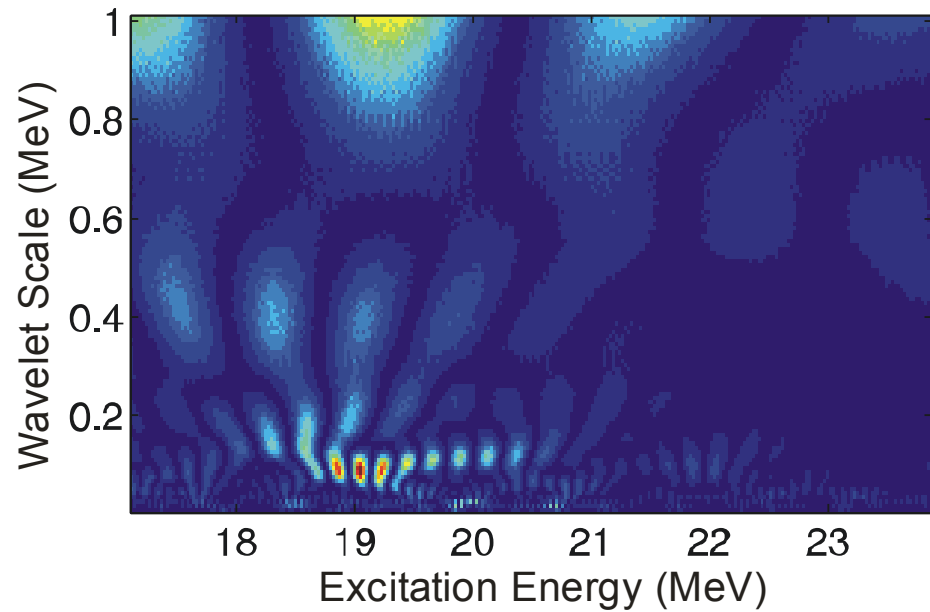
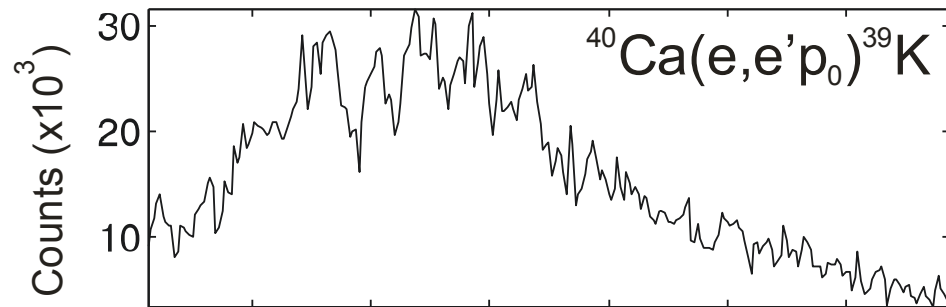
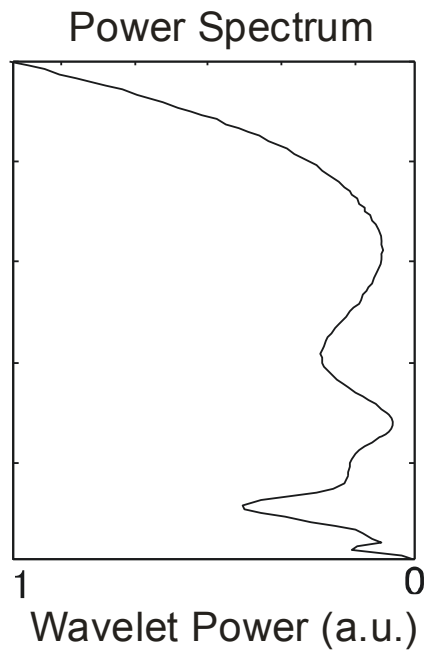

$^{48}\text{Ca}(e,e'n)$

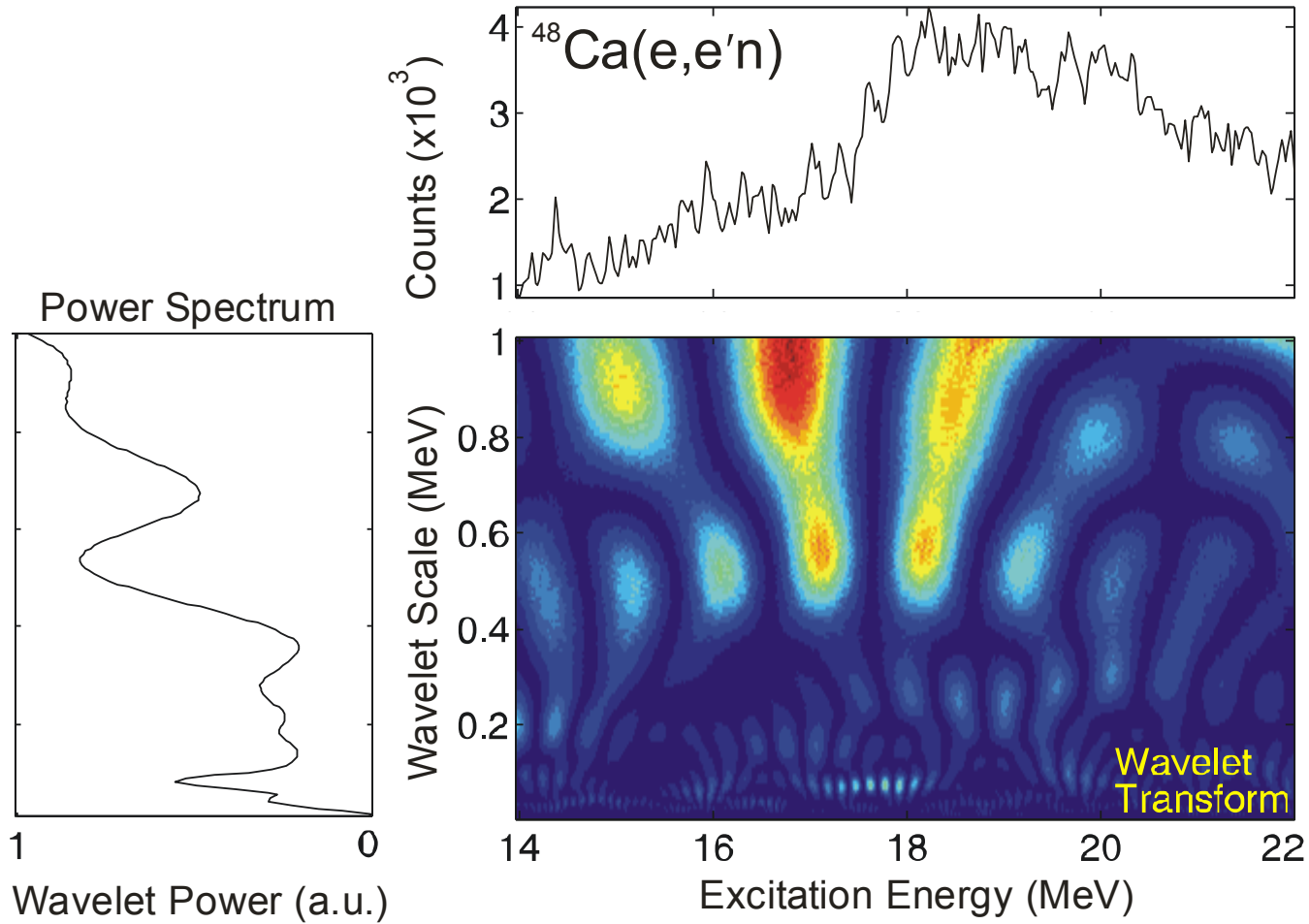

Are All Scales Equally Relevant for the Fine Structure?

Example: Gamow-Teller Giant Resonance

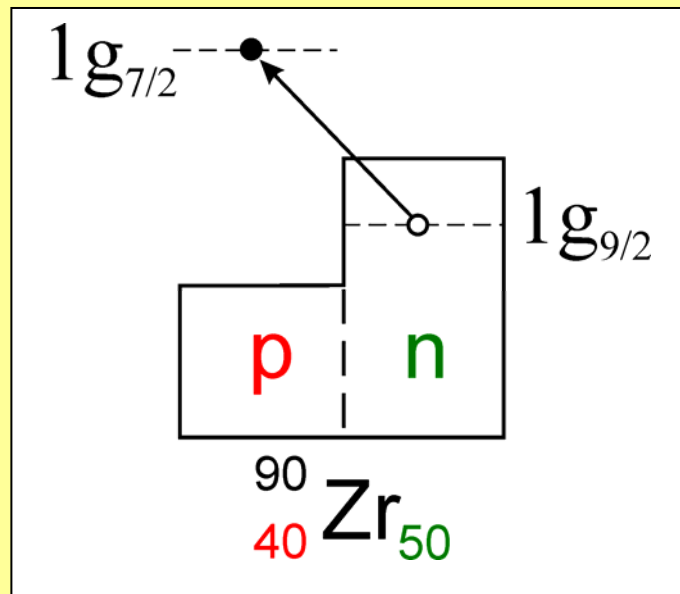

$$\Delta L = 0, \Delta T = 1, \Delta S = 1$$

Fine Structure of the Spin-Flip GTR

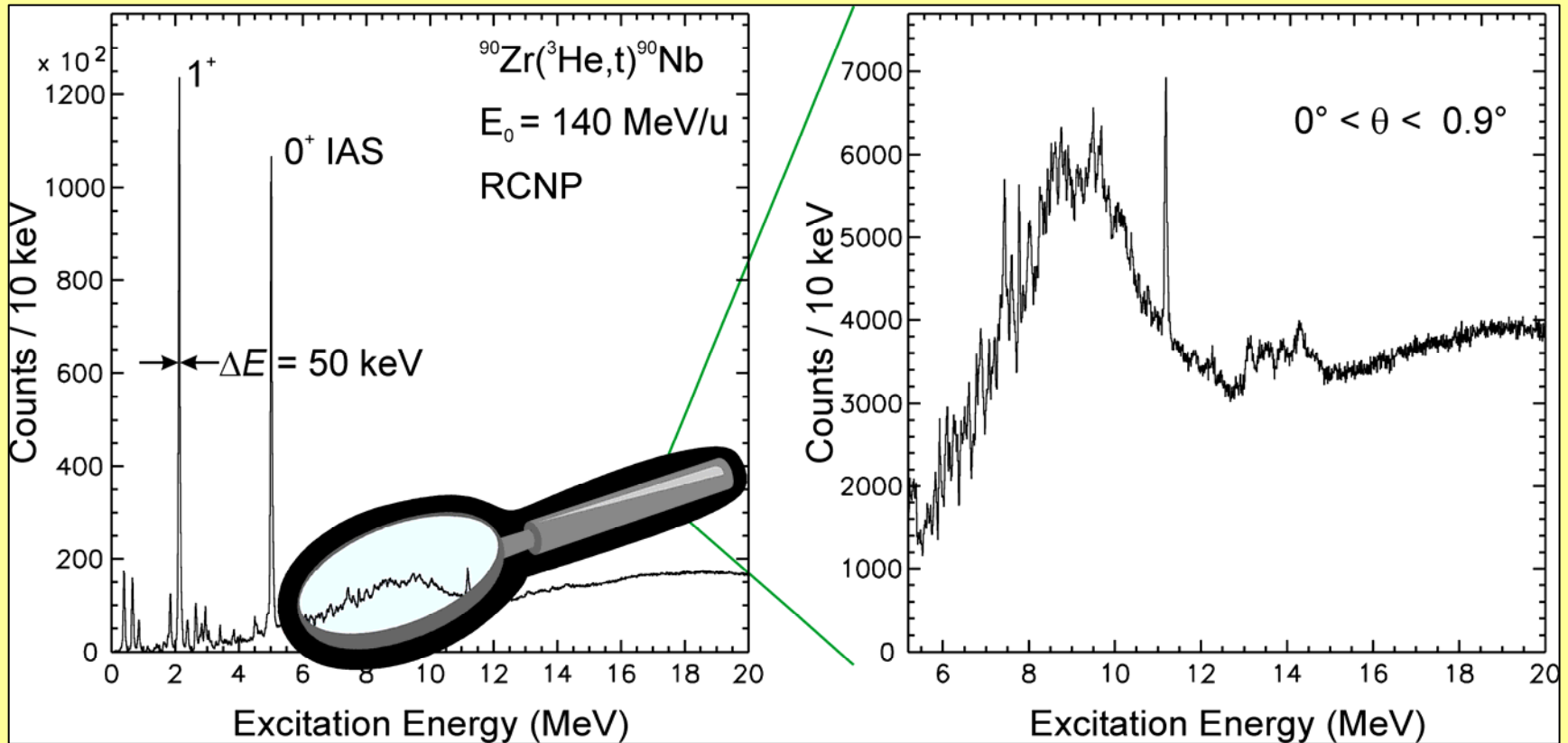

● High energy resolution

● Asymmetric fluctuations

Discrete Wavelet Analysis *

Wavelet coefficients:

$$C(\delta E, E_x) = \frac{1}{\sqrt{\delta E}} \int \sigma(E) \Psi^*\left(\frac{E_x - E}{\delta E}\right) dE$$

↑ ↑ ↑ ↑
scale position spectrum wavelet

Discrete: $\delta E = 2^j$ and $E_x = k \delta E$ with $j, k = 1, 2, 3, \dots$

- Orthogonal basis of wavelet functions (e.g. biorthogonal form)
- Exact reconstruction of the spectrum is possible and it is fast

- Relevance of scales

- $\int_{-\infty}^{+\infty} E^n \Psi^*\left(\frac{E_x - E}{\delta E}\right) dE = 0, \quad n = 0, 1, \dots, m - 1$ vanishing moments

this defines the shape and magnitude of the background

* <http://www.mathworks.com/products/wavelet/>

Decomposition

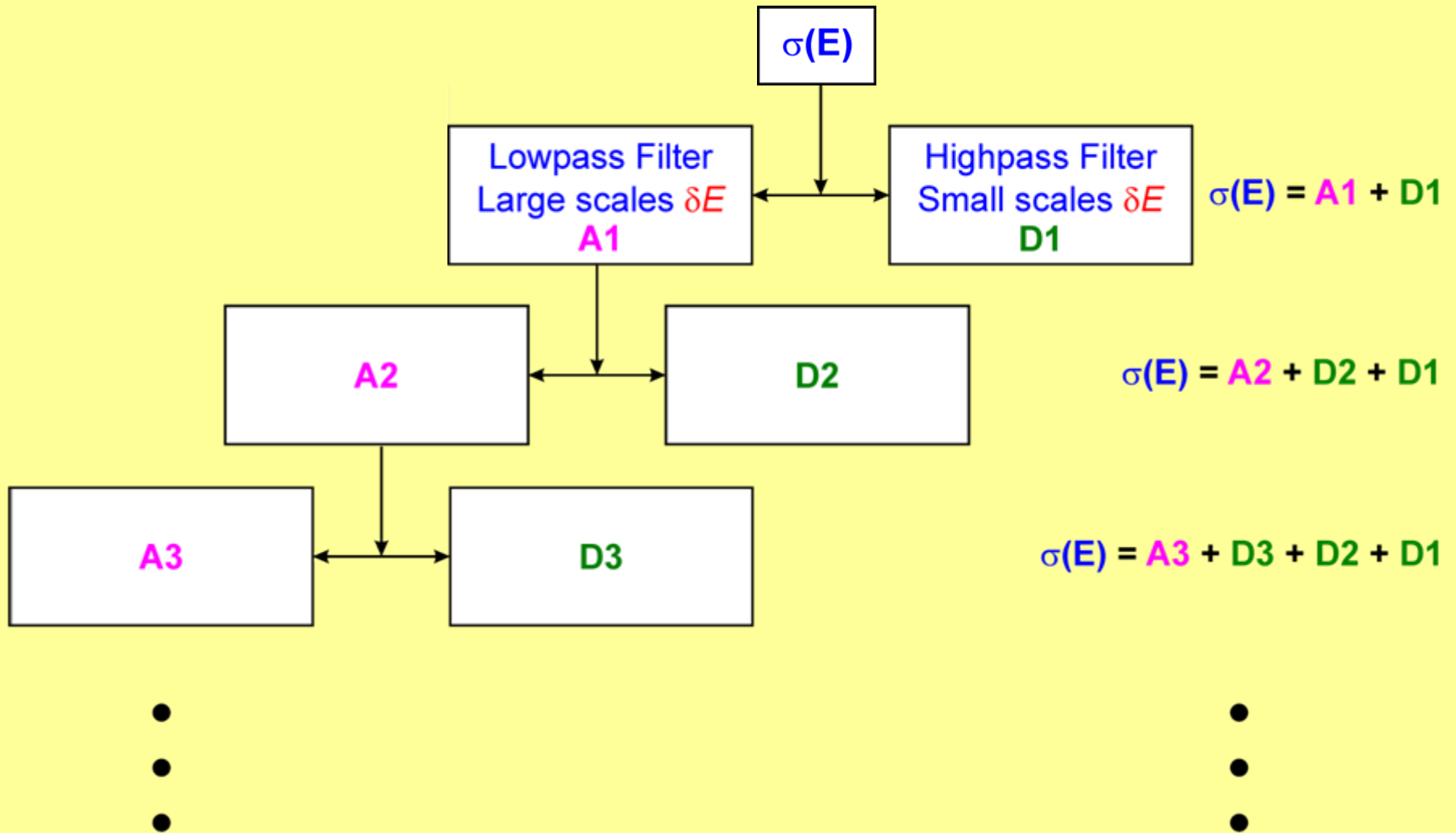

Decomposition of $^{90}\text{Zr}(^3\text{He},t)^{90}\text{Nb}$ Spectrum

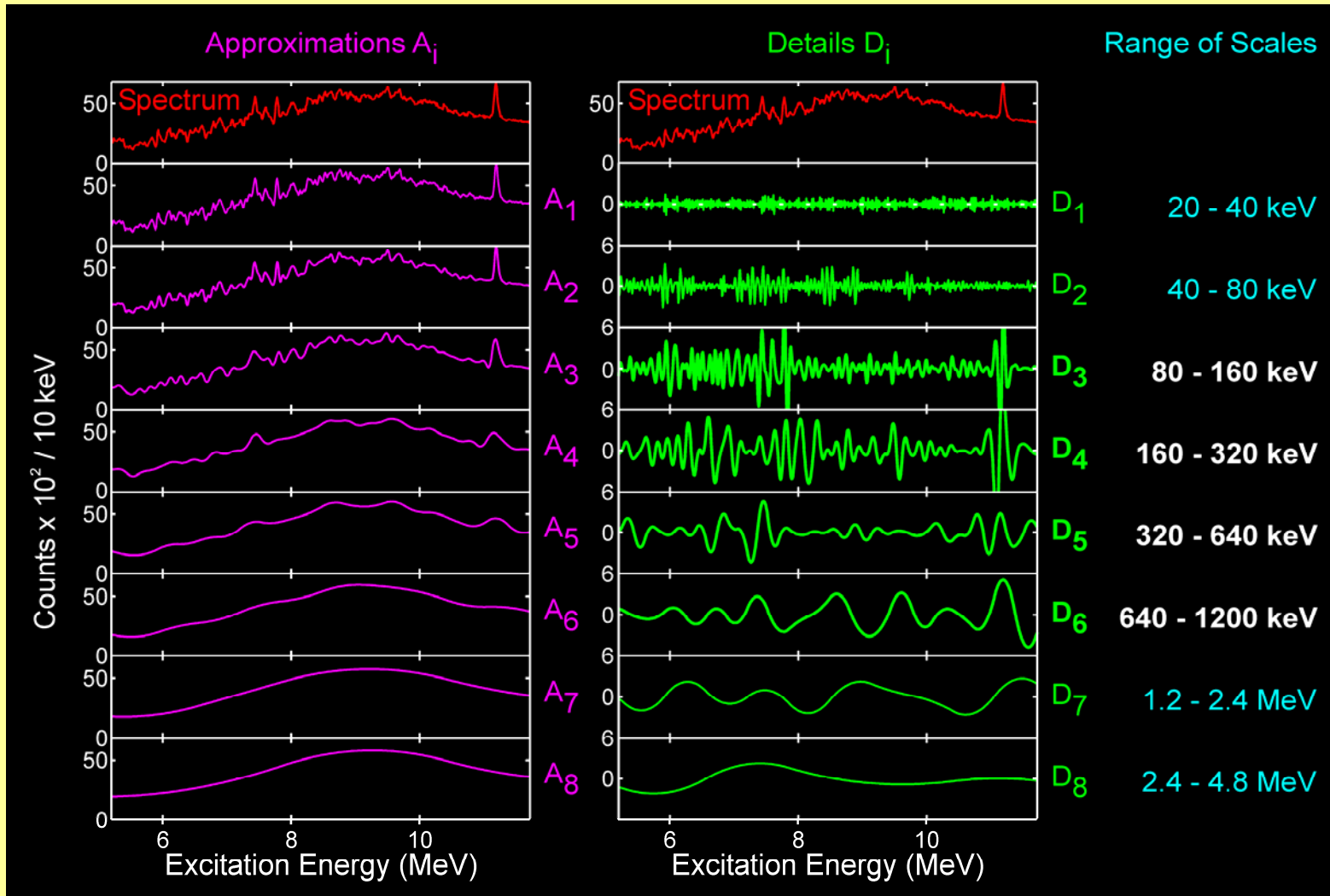

- Reconstruct the spectrum using important scales
- Model-independent background determination + fluctuations \rightarrow level densities

Discrete Wavelet Transform: Reconstructed Spectra

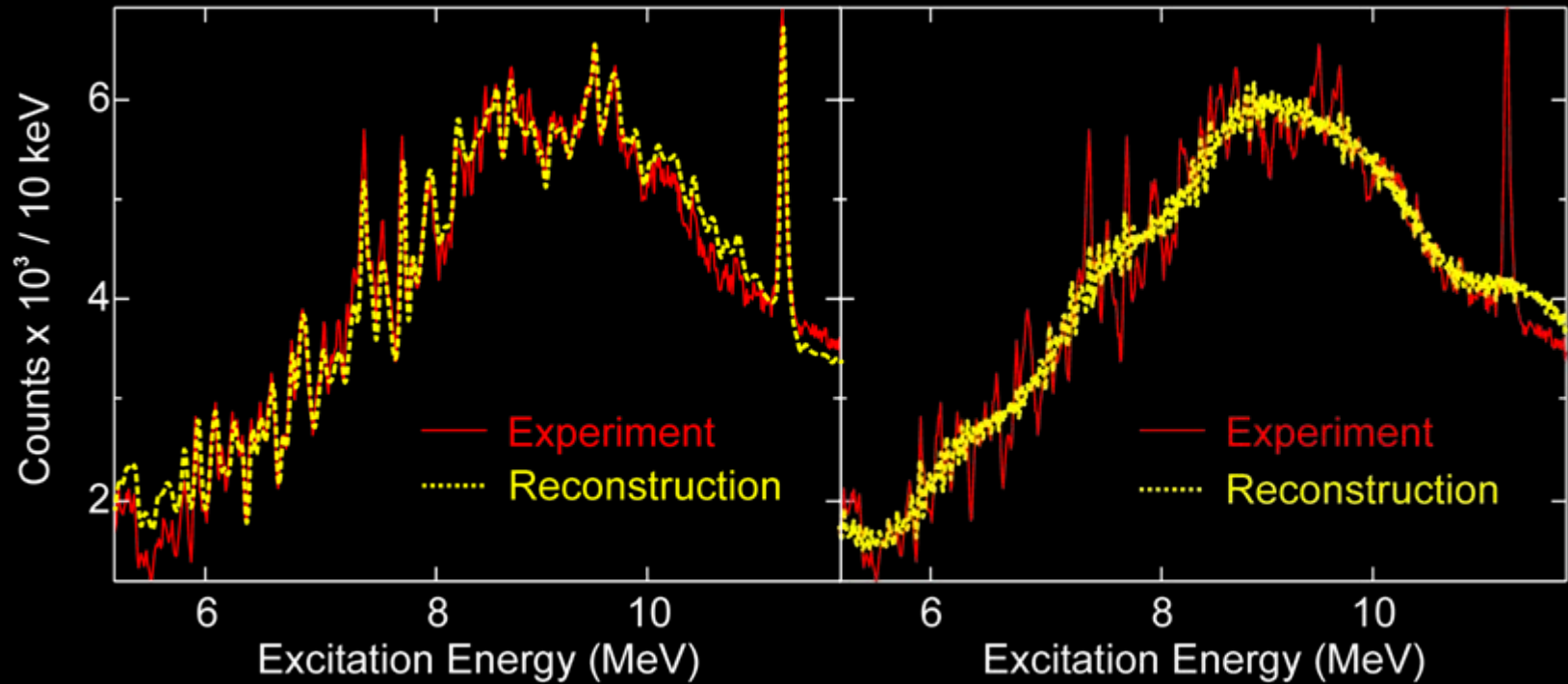

$$\sigma_R(E) = A_8 + D_6 + D_5 + D_4 + D_3$$

$$\sigma_R(E) = A_8 + D_8 + D_7 + D_2 + D_1$$

Level Densities

- Astrophysical network calculations

- Back-shifted Fermi gas model
semiempirical approach
shell and pairing effects

$$\rho(E_x, J) \sim e^{2\sqrt{a(E_x - \delta)}} \cdot e^{-\frac{J(J+1)}{2\sigma^2}}$$

- Many-body density of states
two-component Fermi gas
shell effects, deformations

- HF-BCS
microscopic statistical model (partition function, MSk7 force, local renormalization)
shell effects, pairing correlations, deformation effects, collective excitations

- Monte-Carlo shell model calculations
parity dependence?

Monte-Carlo Shell Model Predictions: pf + g_{9/2} Shell

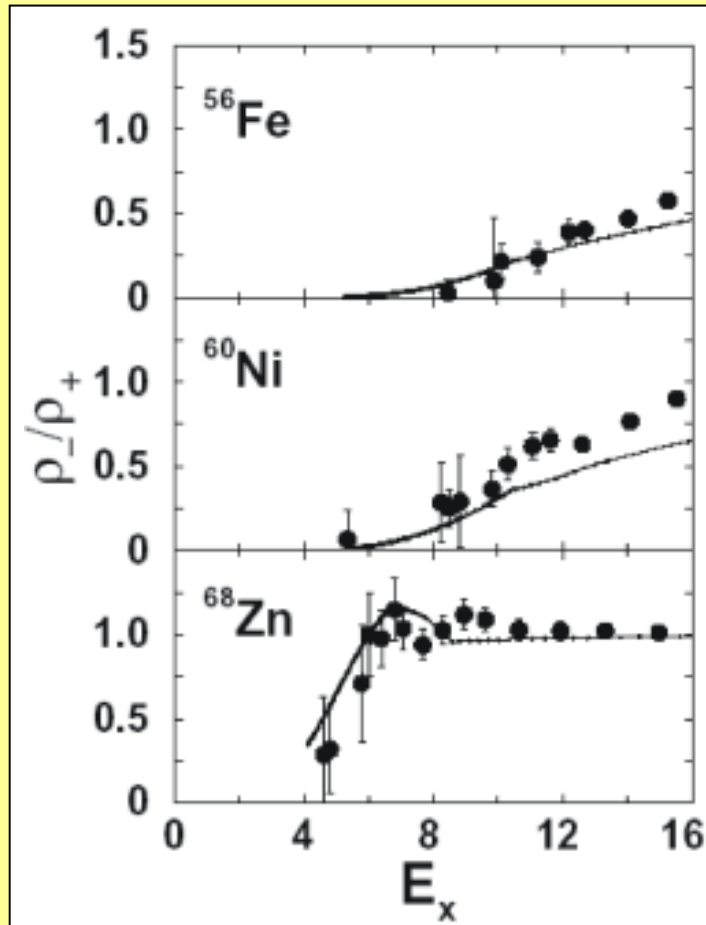

$\Delta_{pf-g_{9/2}}$ small

ρ_- important at low energies

- Total level density (not spin projected) shows strong parity dependence*
- Questioned by recent experiments (⁴⁵Sc)**

* Y. Alhassid, G.F. Bertsch, S. Liu, and H. Nakada, PRL 84 (2000) 4313

** S.J. Lokitz, G.E. Mitchell, and J.F. Shriner, Jr., PRC 71 (2005) 064315

Experimental Techniques

- Selectivity

 - hadron scattering at extremely forward angles and intermediate energies
 - electron scattering at 180° and low momentum transfers

- High resolution

 - lateral and angular dispersion matching
 - faint beam method*

- Level density

 - fluctuation analysis**

- Background

 - discrete wavelet transform***

* H. Fujita et al., NIM A484 (2002) 17

** P.G. Hansen, B. Jonson, and A. Richter, NPA 518 (1990) 13

*** Y. Kalmykov et al., PRL 96 (2006) 012502

Fine Structure of the ISGQR: A = 90

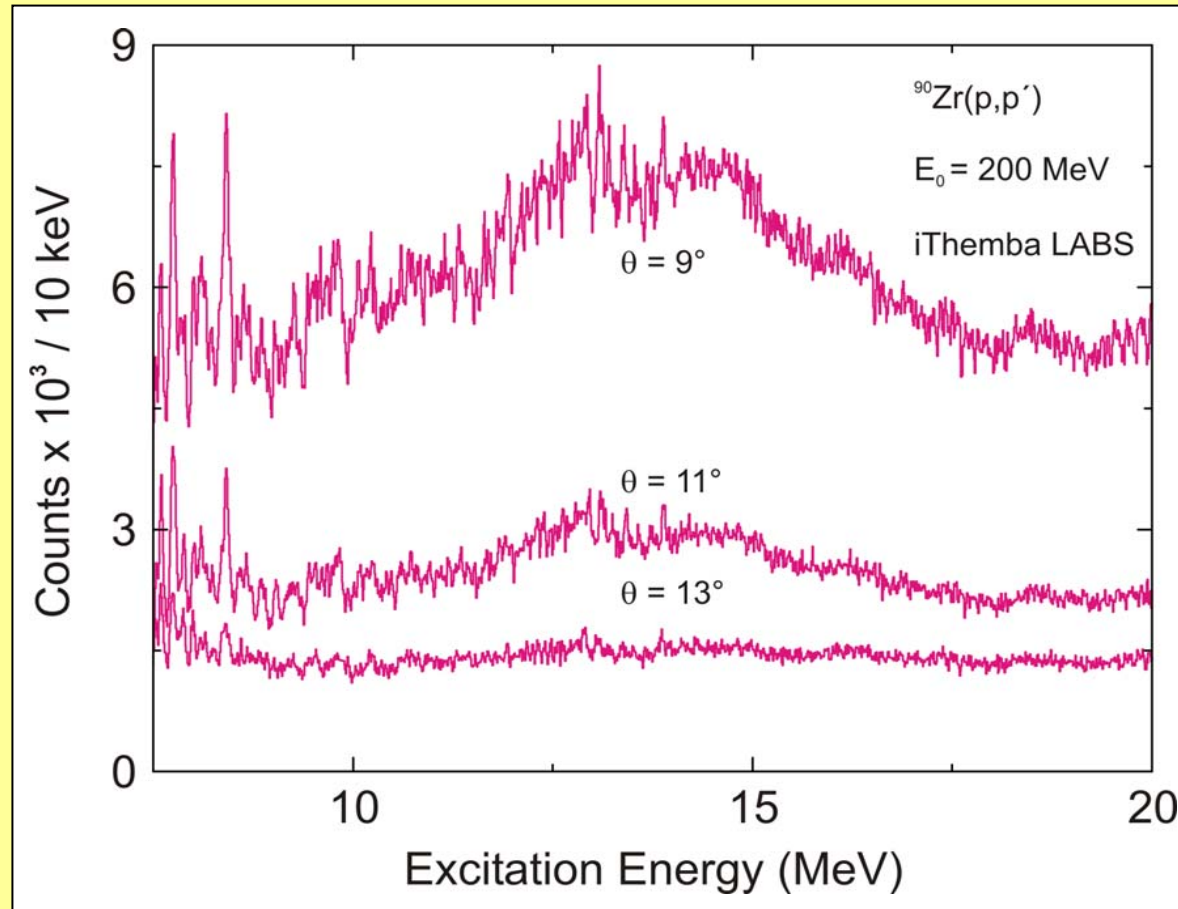

- Selective excitation of 2^+ states

Fine Structure of the M2 Resonance: $A = 90$

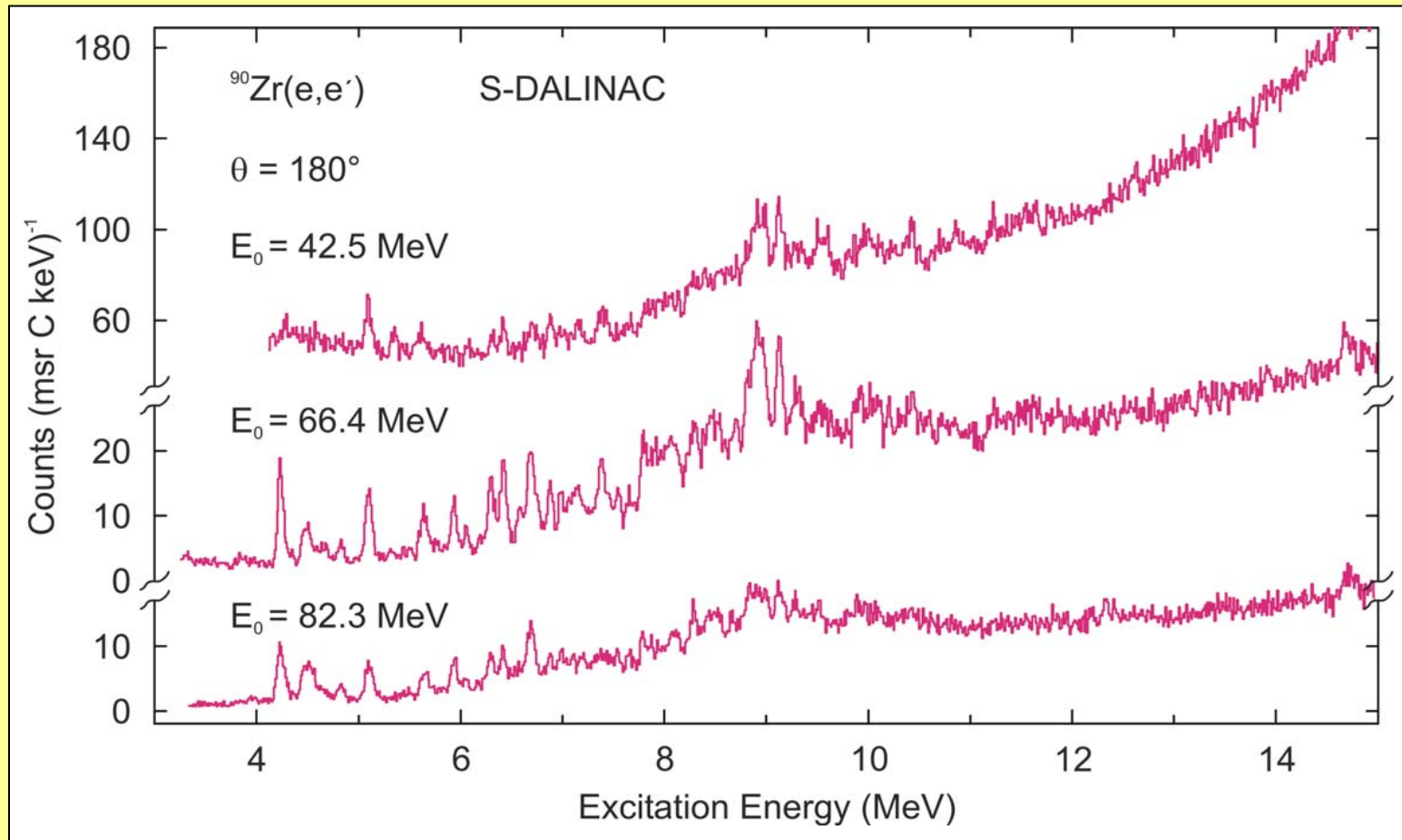

● Selective excitation of 2^- states

Fluctuations and Level Densities

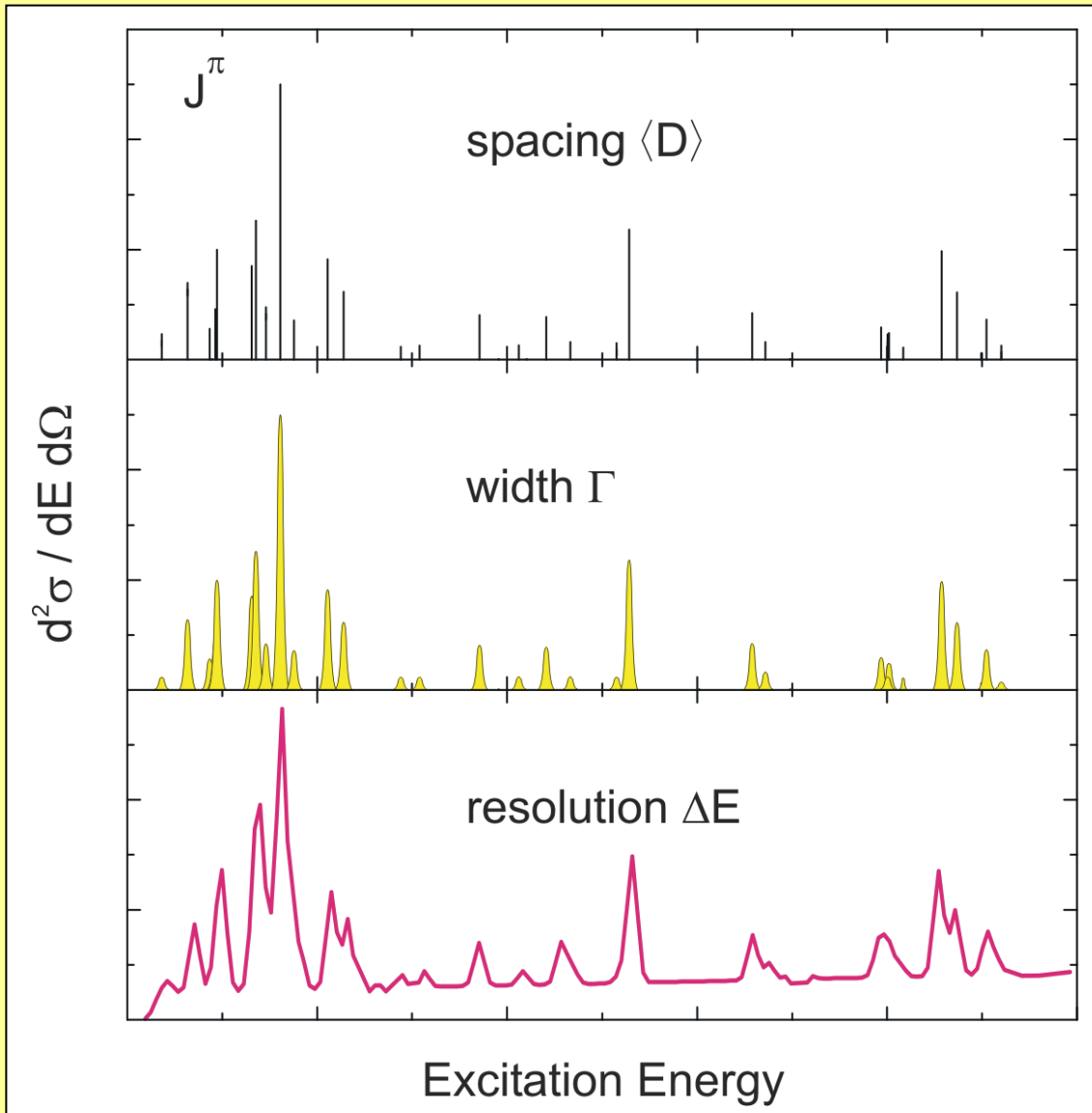

● $D / \langle D \rangle$ Wigner

● $I / \langle I \rangle$ Porter-Thomas

→ 4th Lecture

● $\Gamma < \langle D \rangle$

● $\Gamma < \langle D \rangle < \Delta E$

Fluctuation Analysis

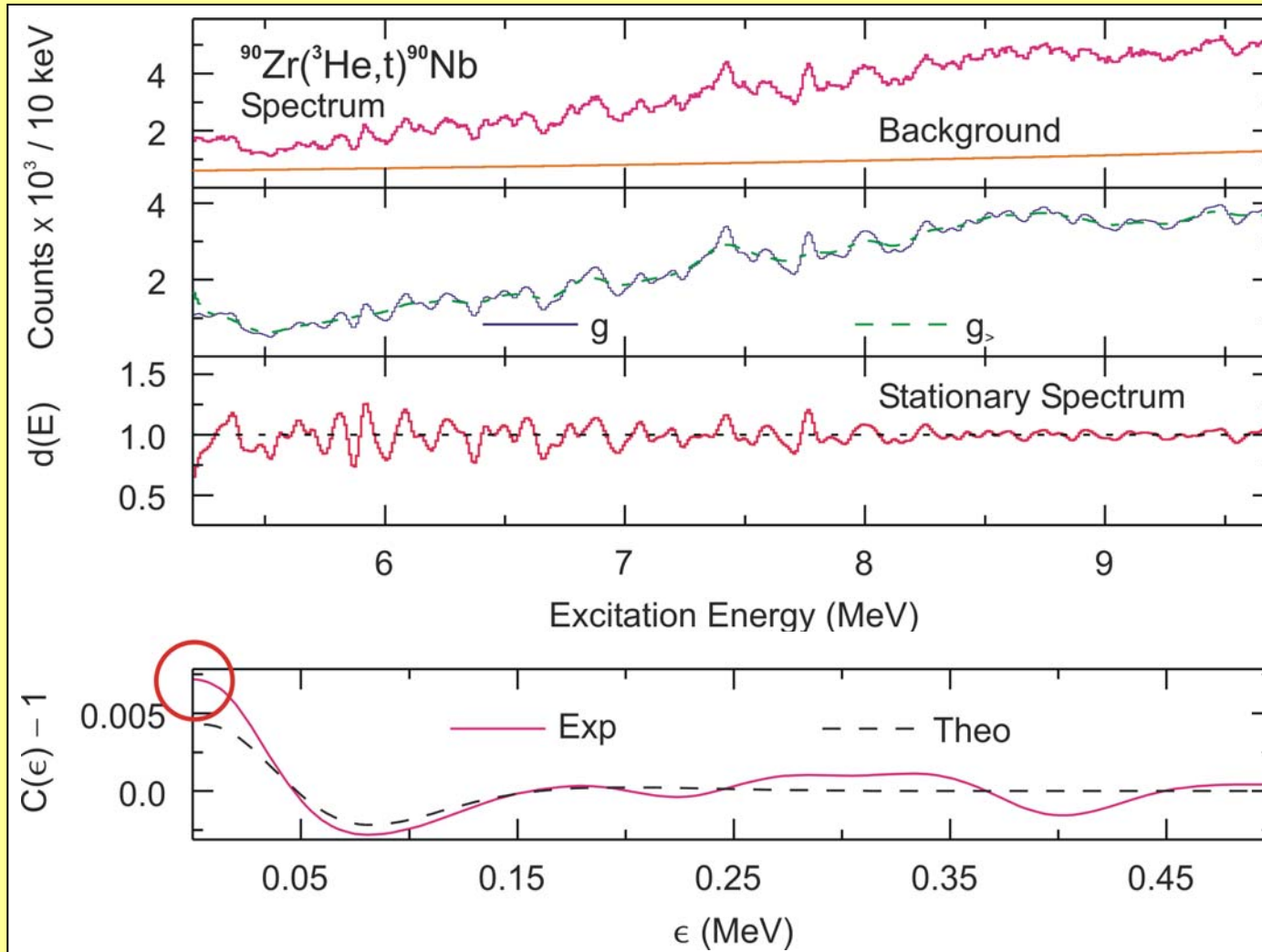

- Background from wavelet analysis
- Statistics, local features
- Local fluctuations
- Autocorrelation function

Autocorrelation Function and Mean Level Spacing

• $C(\varepsilon) = \frac{\langle d(E_x) d(E_x + \varepsilon) \rangle}{\langle d(E_x) \rangle \langle d(E_x + \varepsilon) \rangle}$ autocorrelation function

• $C(\varepsilon = 0) - 1 = \frac{\langle d^2(E_x) \rangle - \langle d(E_x) \rangle^2}{\langle d(E_x) \rangle^2}$ variance

• $C(\varepsilon) - 1 = \frac{\alpha \langle D \rangle}{2\sigma\sqrt{\pi}} \times f(\sigma, \varepsilon)$ level spacing $\langle D \rangle$

• $\alpha = \alpha_{PT} + \alpha_W$ selectivity

• σ resolution

S. Müller, F. Beck, D. Meuer, and A. Richter, PLB 113 (1982) 362

P.G. Hansen, B. Jonson, and A. Richter, NPA 518 (1990) 13

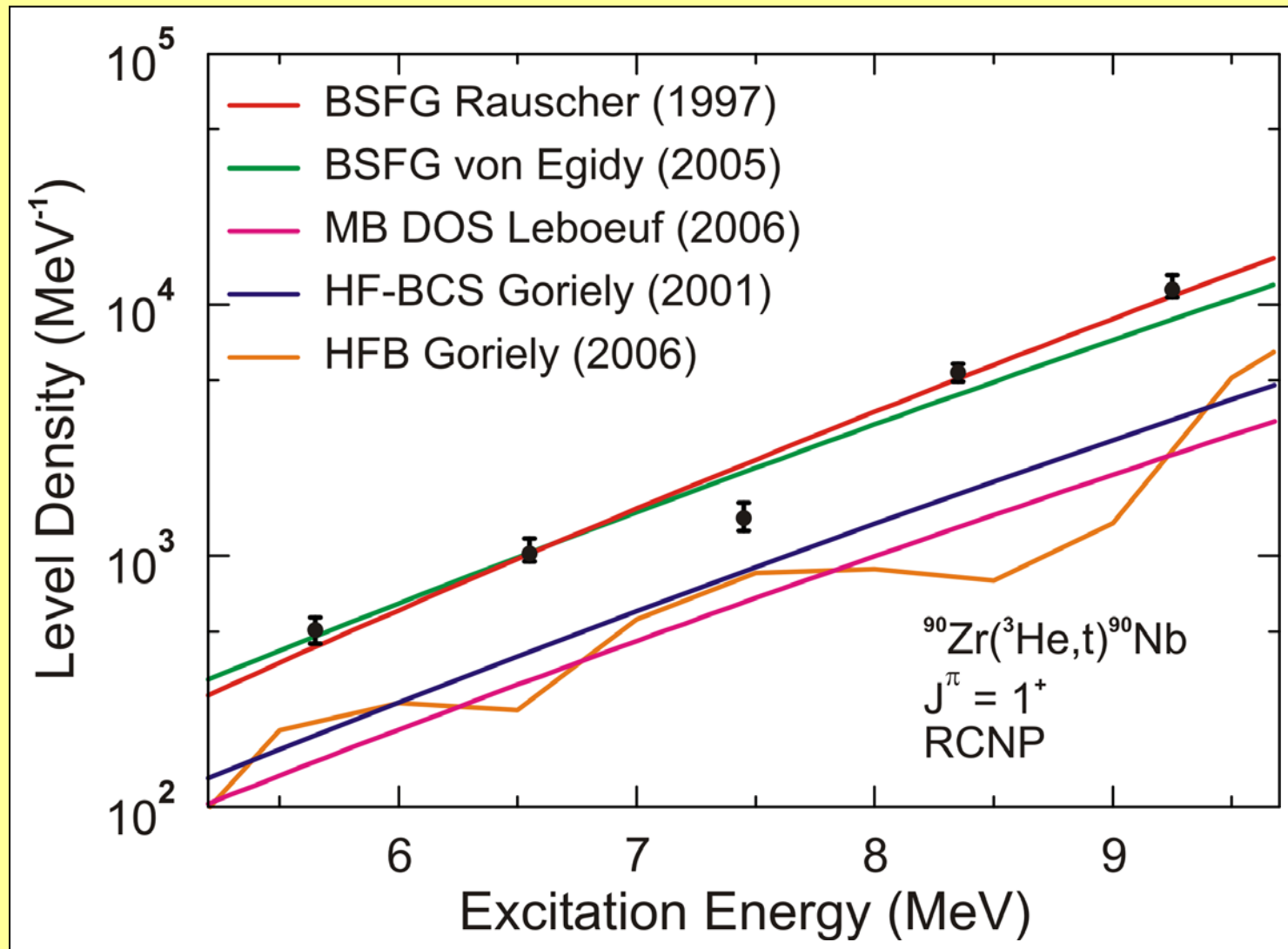

Results and Model Predictions: $A = 90$, $J^\pi = 1^+$

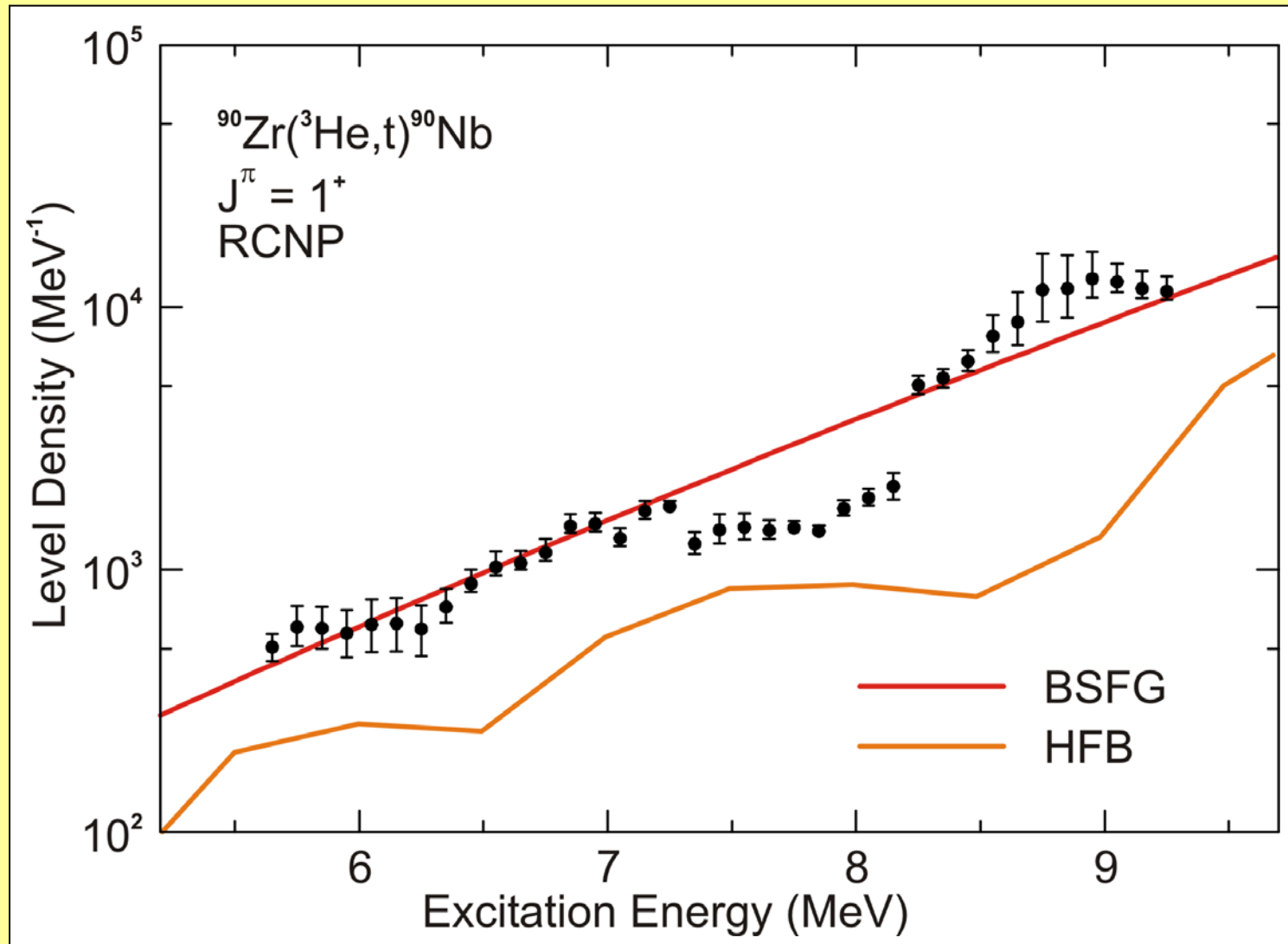

Fine Structure of Level Density: $A = 90$, $J^\pi = 1^+$



Phenomenological and Microscopic Models

- Different quality of model predictions
- BSFG, MB DOS
 - parameters fitted to experimental data
 - no distinction of parity
- HF-BCS
 - microscopic
 - no distinction of parity
- HFB, SMMC 
 - fully microscopic calculation of levels
 - with spin and parity
- HFB 
 - fine structure of level densities

Ingredients of HFB

- Nuclear structure: HFB calculation with a conventional Skyrme force
 - single particle energies
 - pairing strength for each level
 - quadrupole deformation parameter
 - deformation energy

- Collective effects
 - rotational enhancement
 - vibrational enhancement
 - disappearance of deformation at high energies

Ingredients of SMMC

- Partition function of many-body states with good J^π

$$Z_J^\pi(\beta) = \text{Tr}_{J,\pi} e^{-\beta H}$$

- Expectation values at inverse temperature $\beta = 1/kT$

$$E_J^\pi(\beta) = \frac{\int dE' e^{-\beta E'} E' \rho_J^\pi(E')}{Z_J^\pi(\beta)}$$

- Level density from inverse Laplace transform in the saddle-point approximation

$$\rho_J^\pi(\beta) = \frac{e^{\beta E_J^\pi + \ln Z_J^\pi(\beta)}}{\sqrt{-2\pi \frac{dE_J^\pi(\beta)}{d\beta}}}$$

Level Density of 2^+ and 2^- States: ^{90}Zr

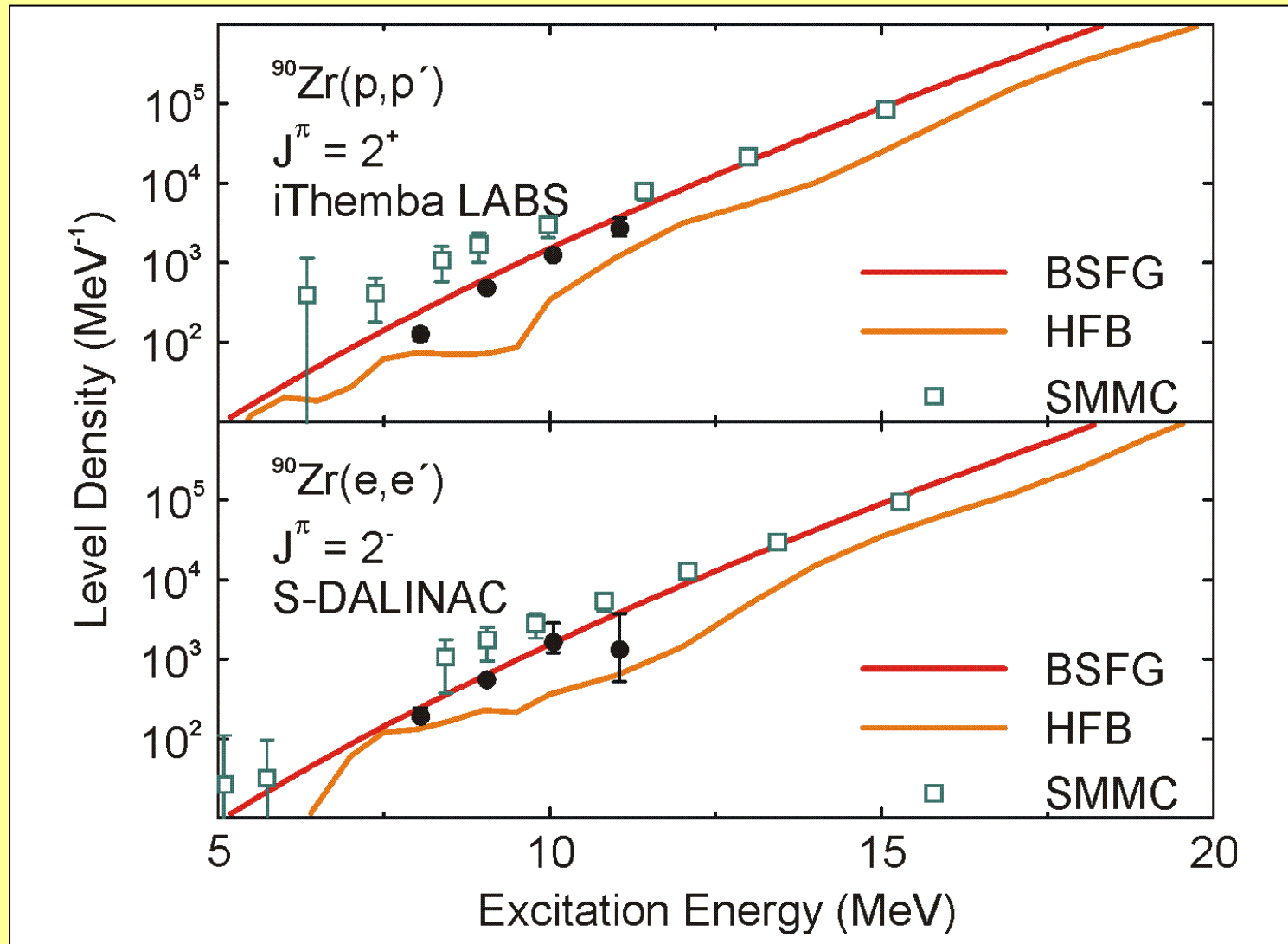

Equilibration of Parity-Projected Level Densities

- ^{58}Ni

$$\rho_- \approx \rho_+ \text{ at } E_x \approx 20 \text{ MeV}$$

- ^{90}Zr

$$\rho_- \approx \rho_+ \text{ at } E_x \approx 5 - 10 \text{ MeV}$$

- Two energy scales which determine ρ_-/ρ_+
pair-breaking

 - ➔ 5 – 6 MeV for intermediate mass nuclei

 - shell gap between opposite-parity states near the Fermi level

 - ➔ depends strongly on the shell structure, e.g. ^{68}Zn $\Delta_{pf-g9/2}$ is small

- Core breaking

 - e.g. near shell closure ^{58}Ni Δ_{sd-pf} transitions are important

 - ➔ ρ_- would be enlarged



Summary

- Fine structure is a general phenomenon of many-body systems (particles, nuclei, atoms, molecules, clusters, condensates,...)
- Quantitative analysis of nuclear giant resonances with wavelets
- Origin of scales in GR's:
 - collective damping: low-lying surface vibrations
 - non-collective damping: stochastic coupling
- New method for level densities

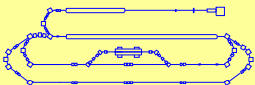

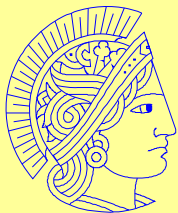

Outlook

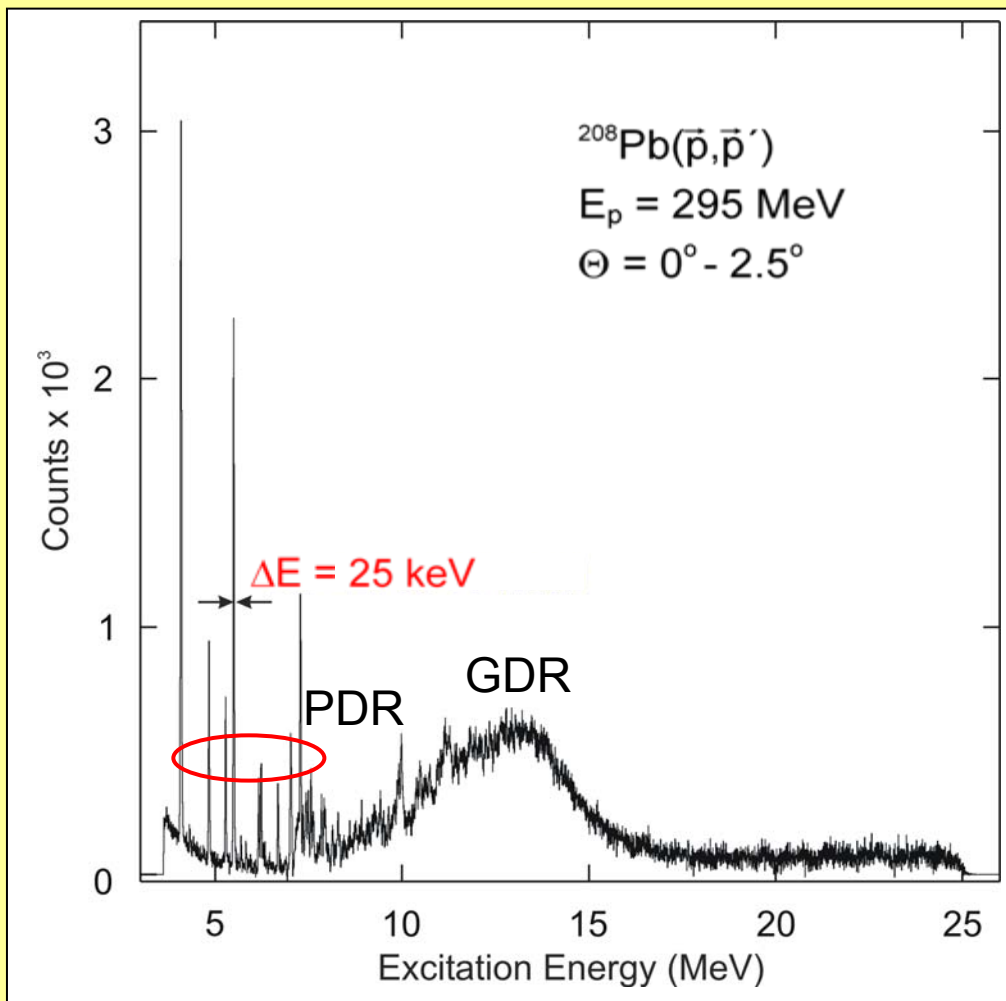

→ 3rd Lecture

