

Jets in Hot, Dense Nuclear Matter

Or, how high-energy physics intruded into nuclear physics and got its comeuppance

Paul Stankus

Oak Ridge National Laboratory

NNPSS 08

What is a jet?

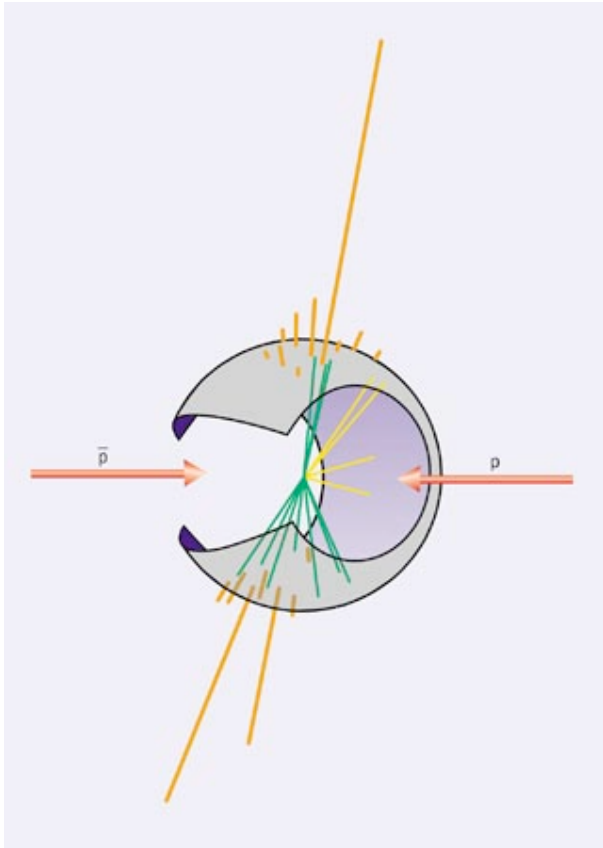

A UA2 two-jet event, ca 1982

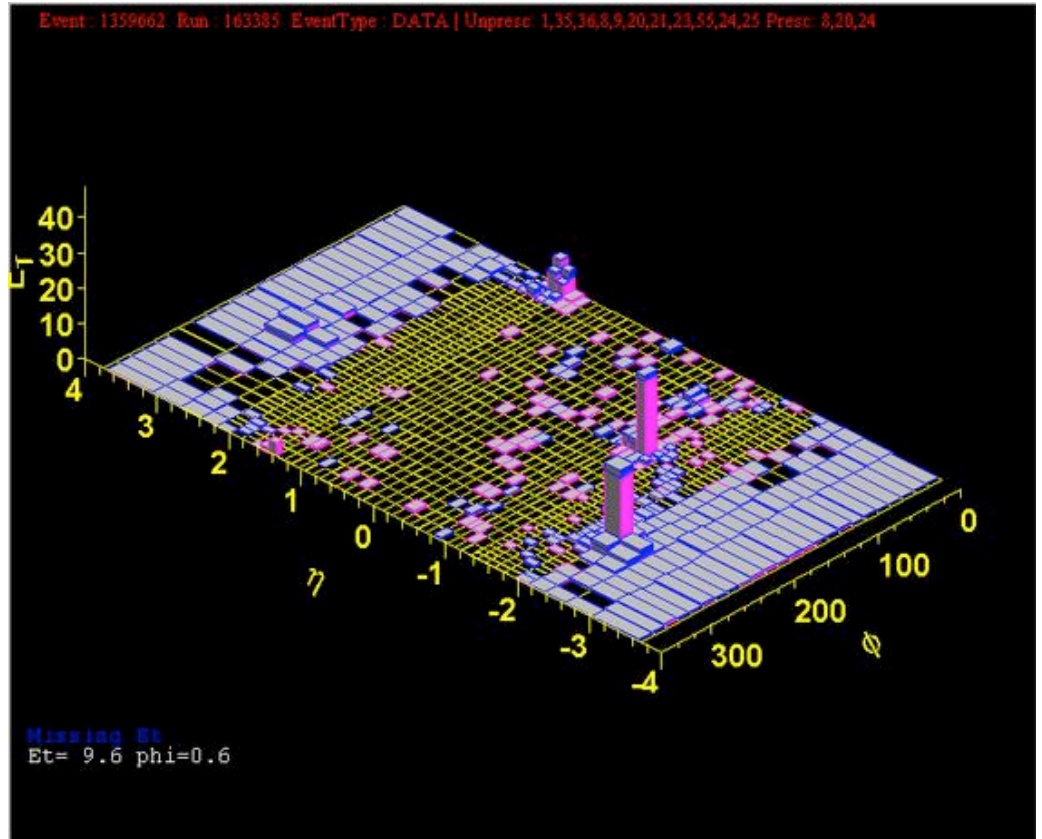

On-line from D0, ca 2003



Side-to-beam view

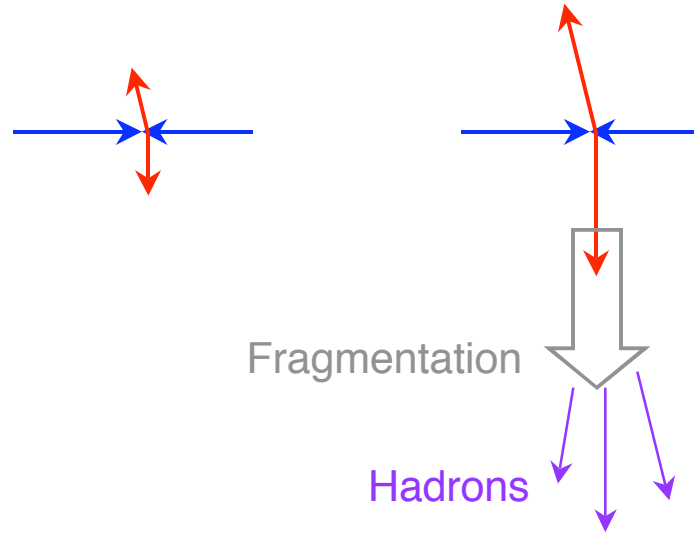

Along-the-beam view

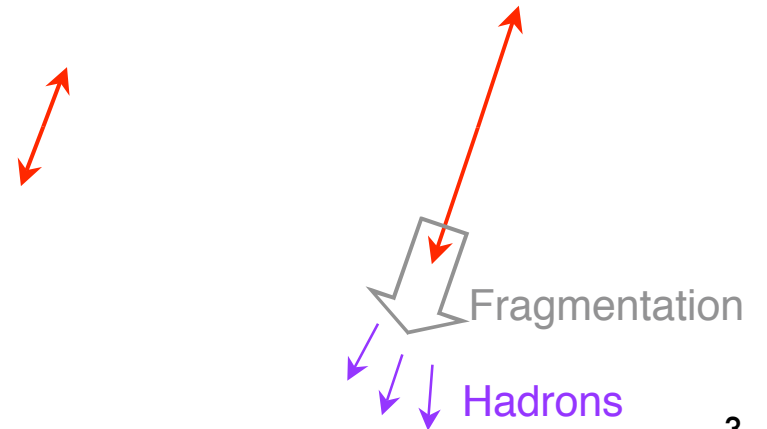

Side-to-beam view

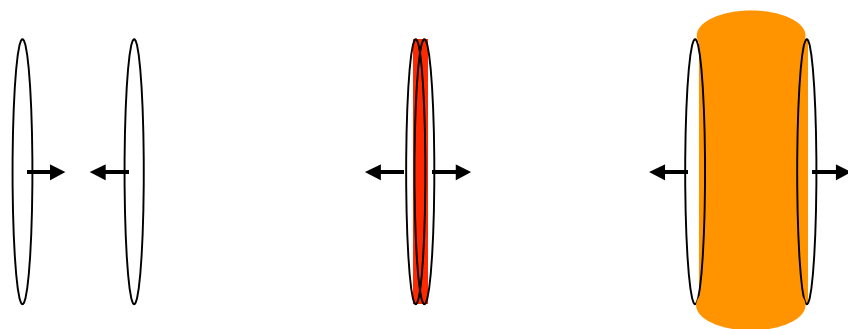

Hot Zone

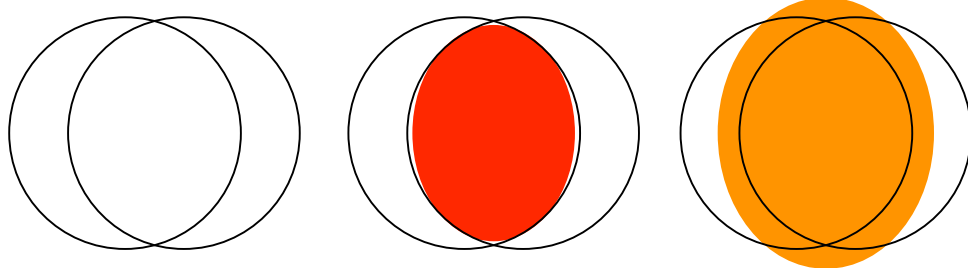

Along-the-beam view

STAR Experiment at RHIC

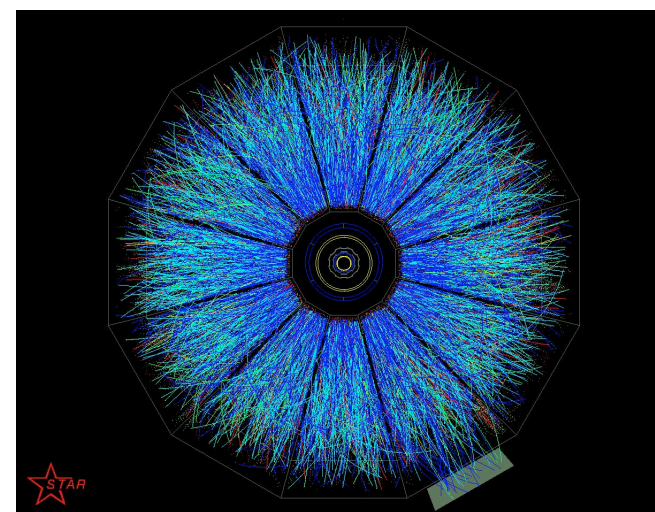
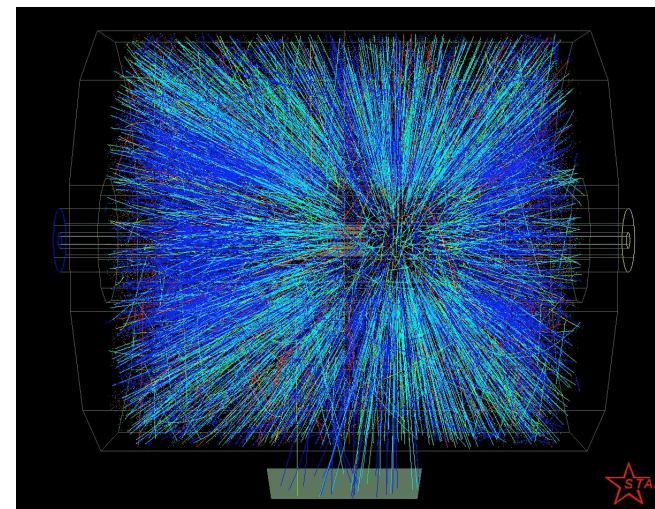

Au+Au at $\sqrt{s_{NN}} = 200$ GeV

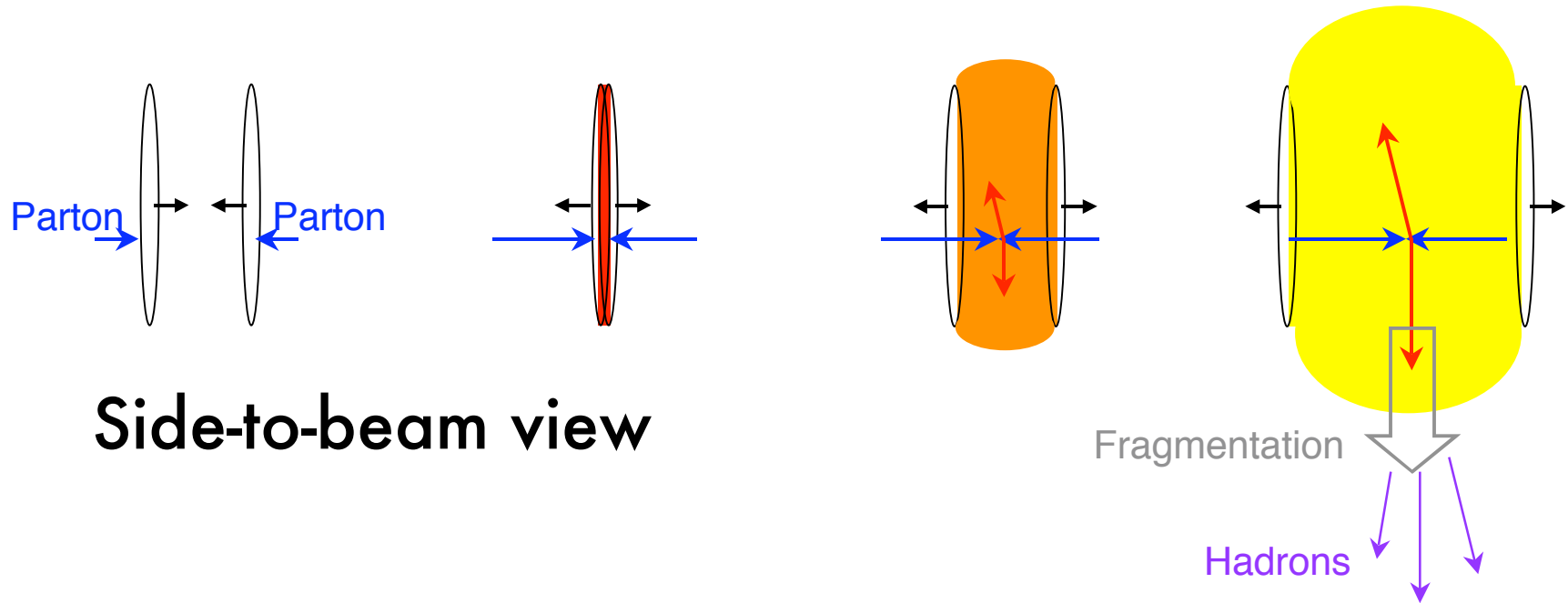

Side-to-beam view

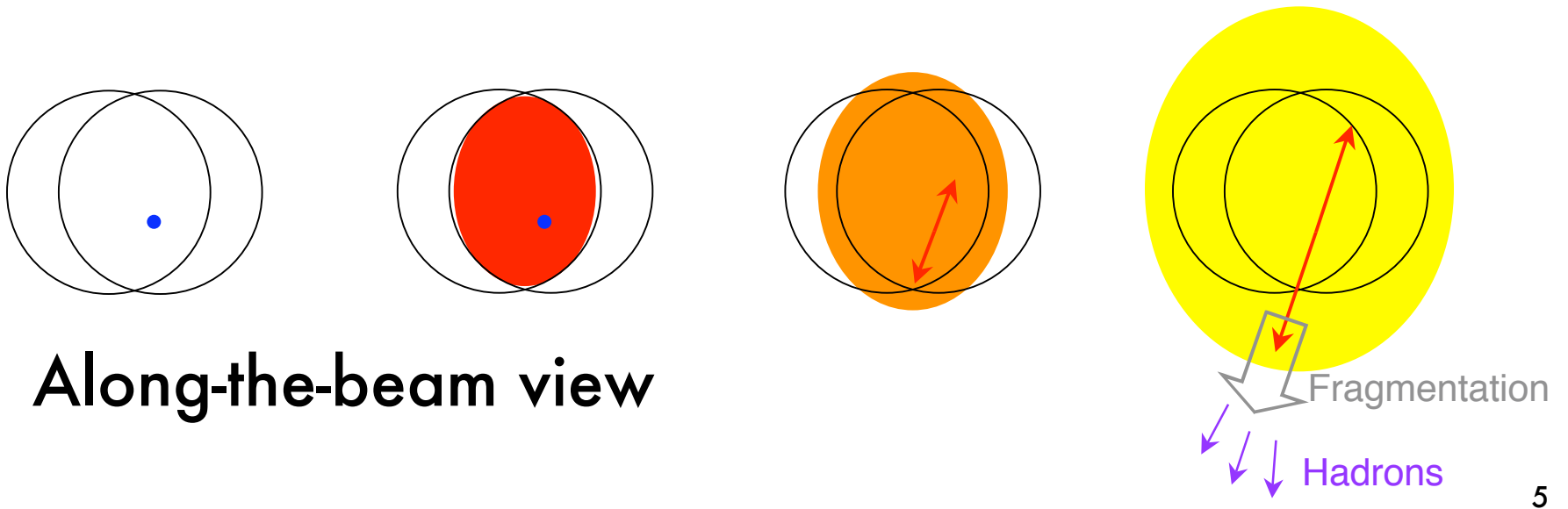

Along-the-beam view

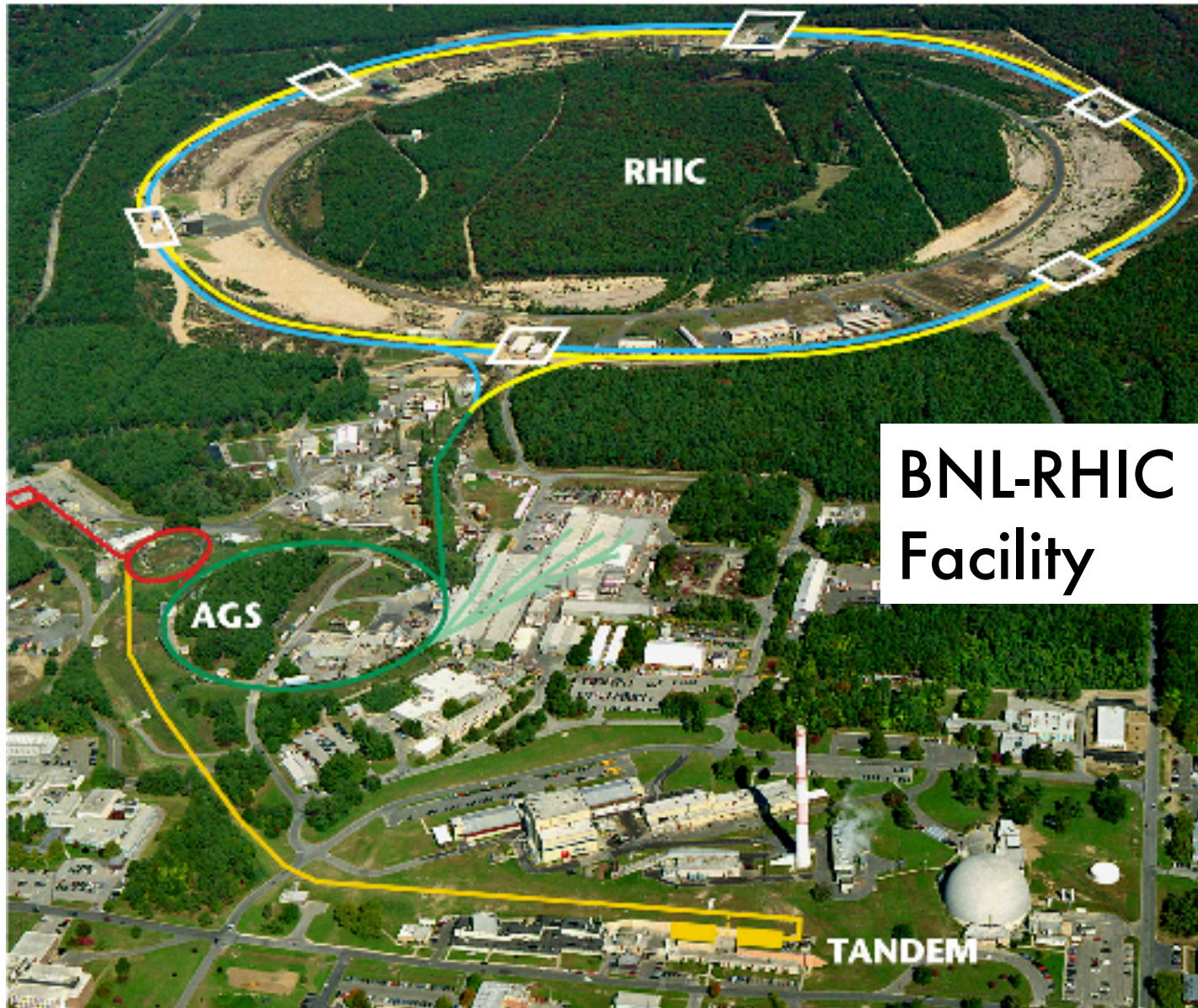

Also: BNL-AGS, CERN-SPS, CERN-LHC

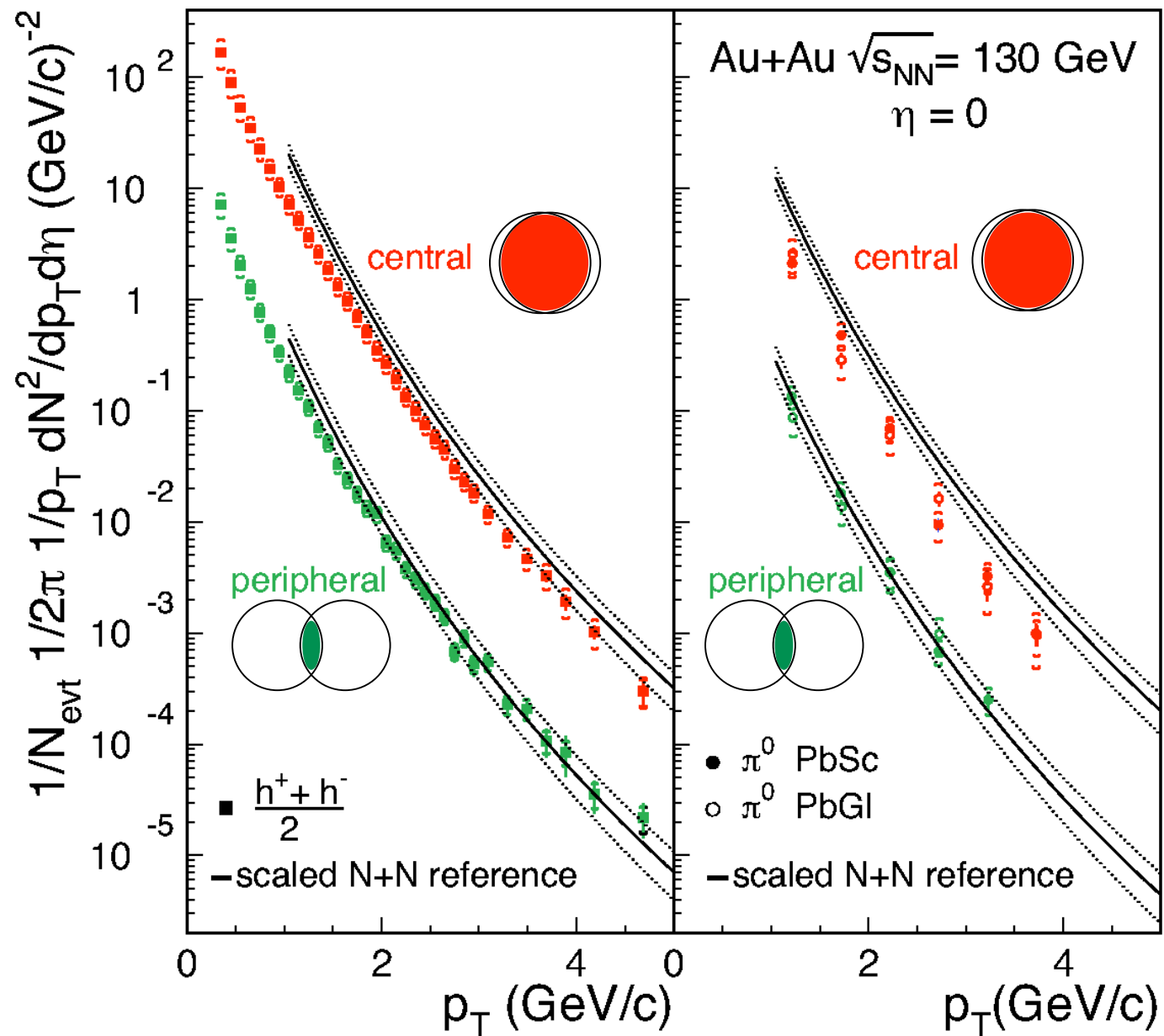

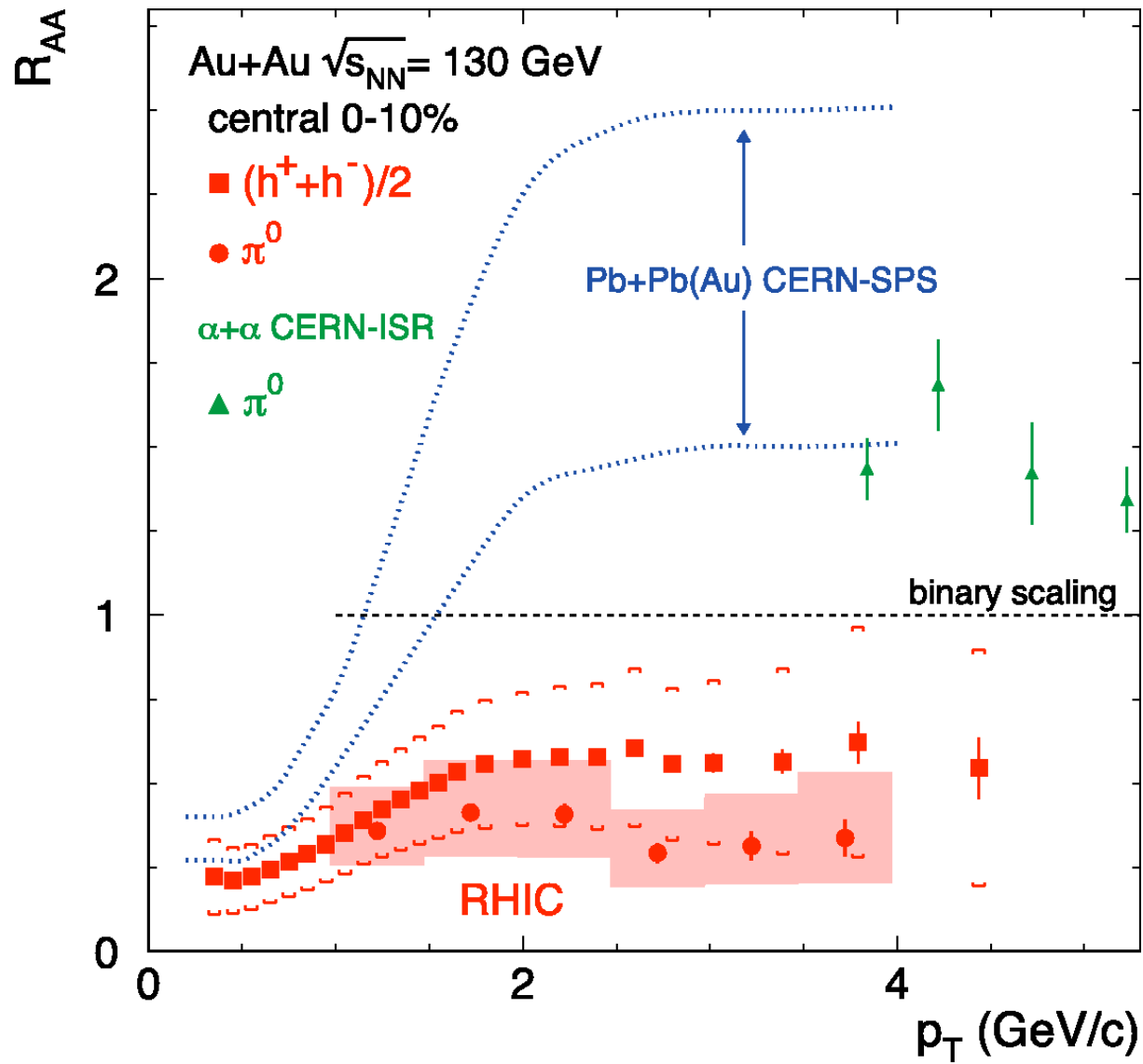

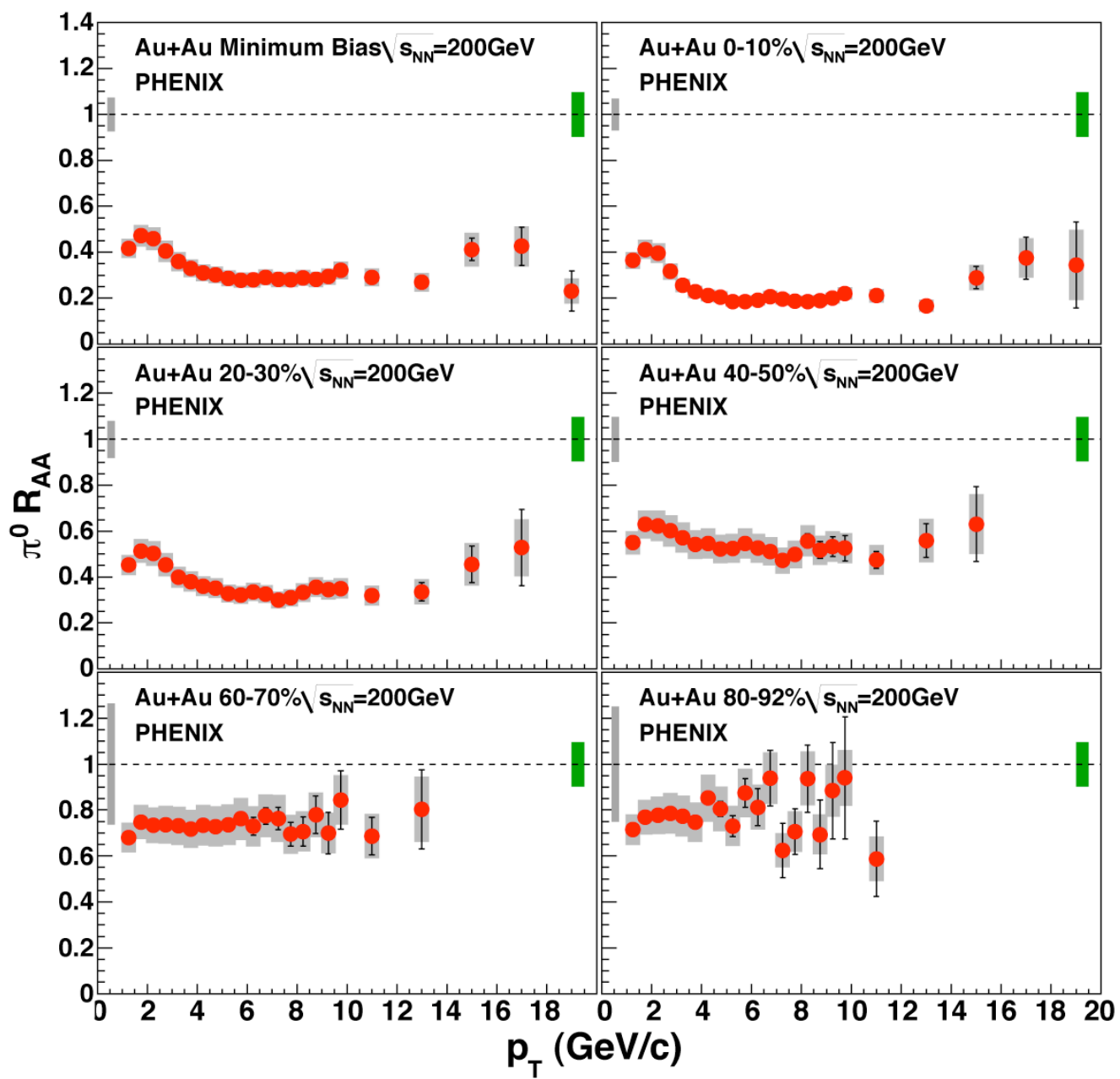

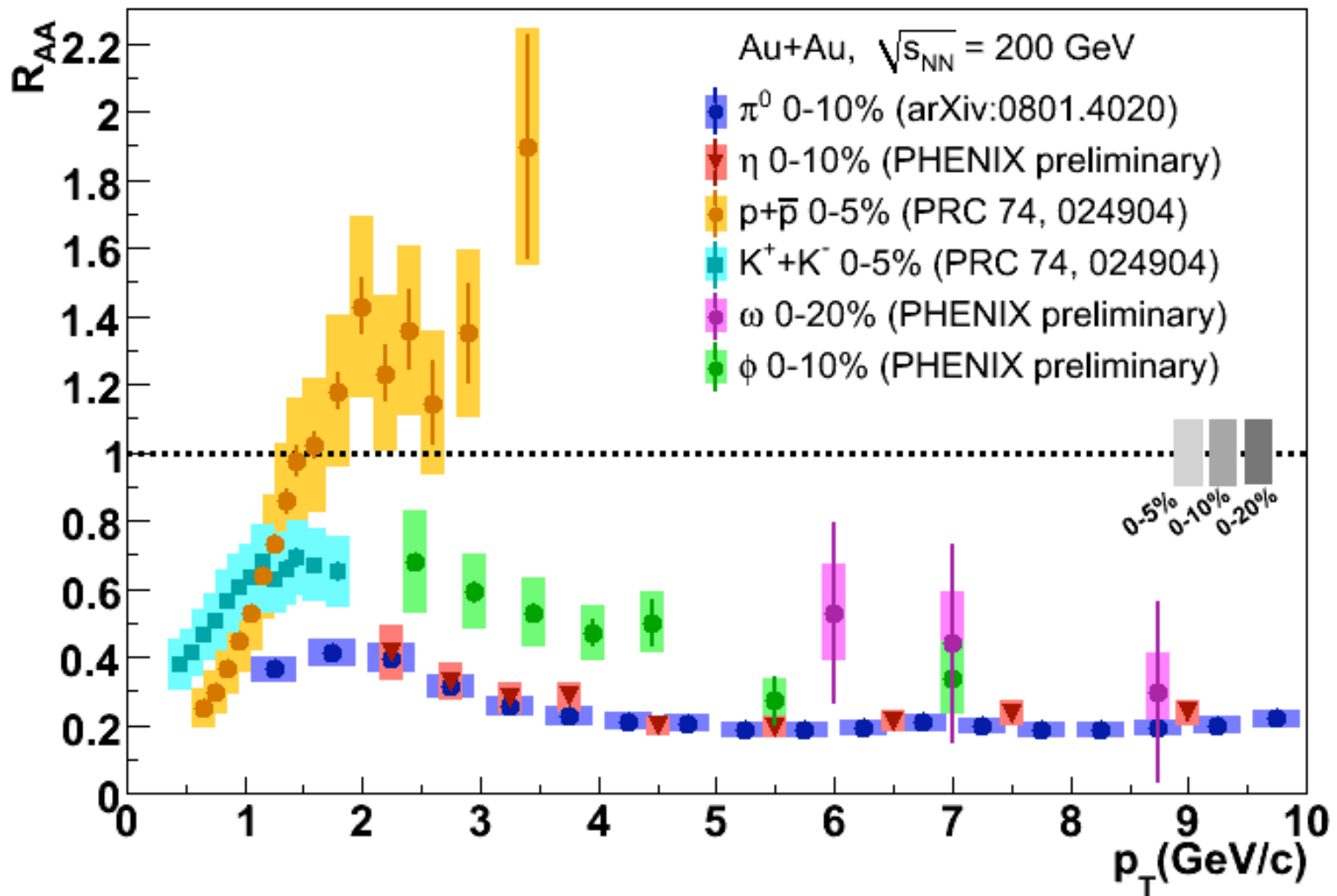

Au+Au $\sqrt{s_{NN}} = 200\text{GeV}$, 0-10%

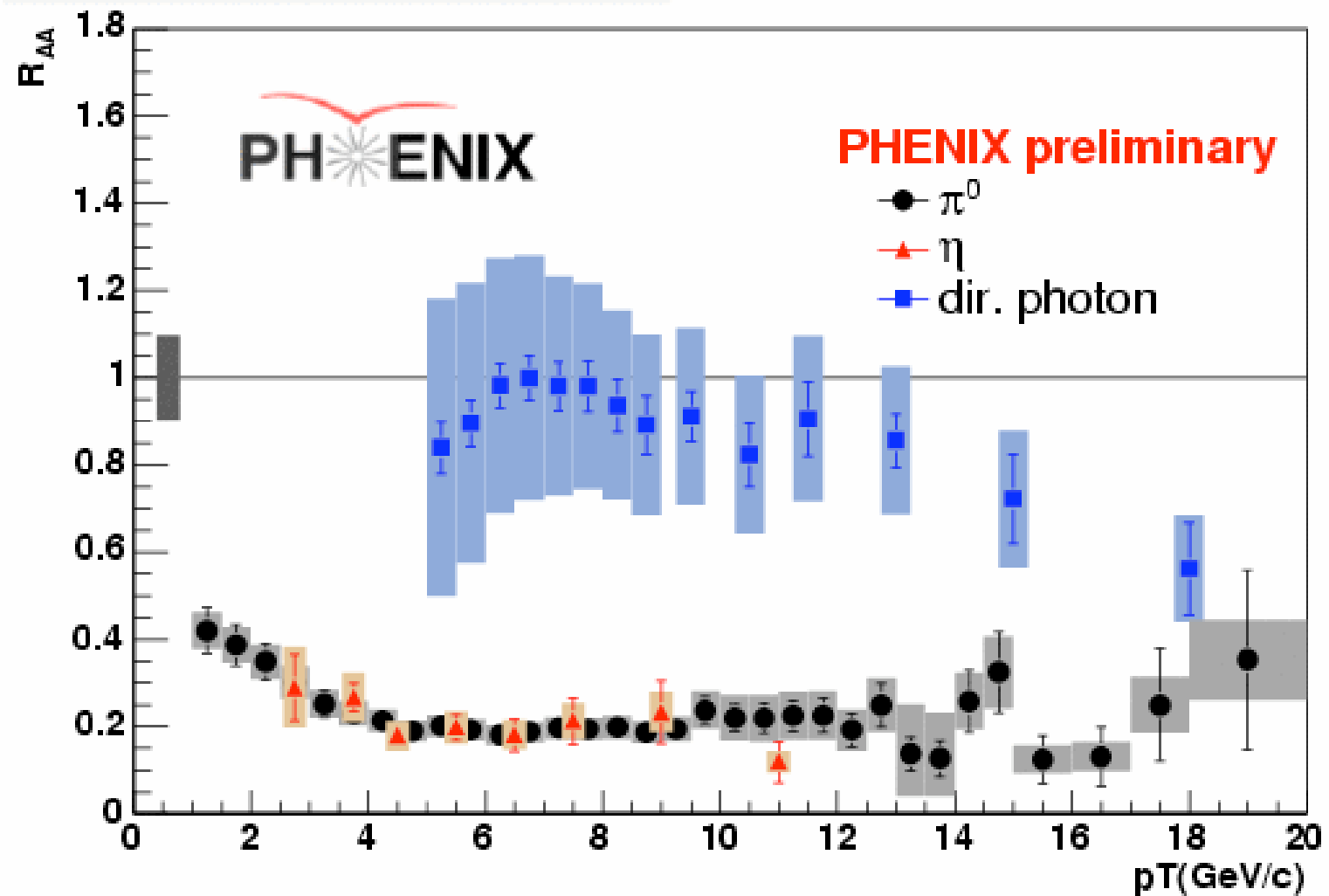

Two-Source Model

Prompt
“Jet 1”
Source

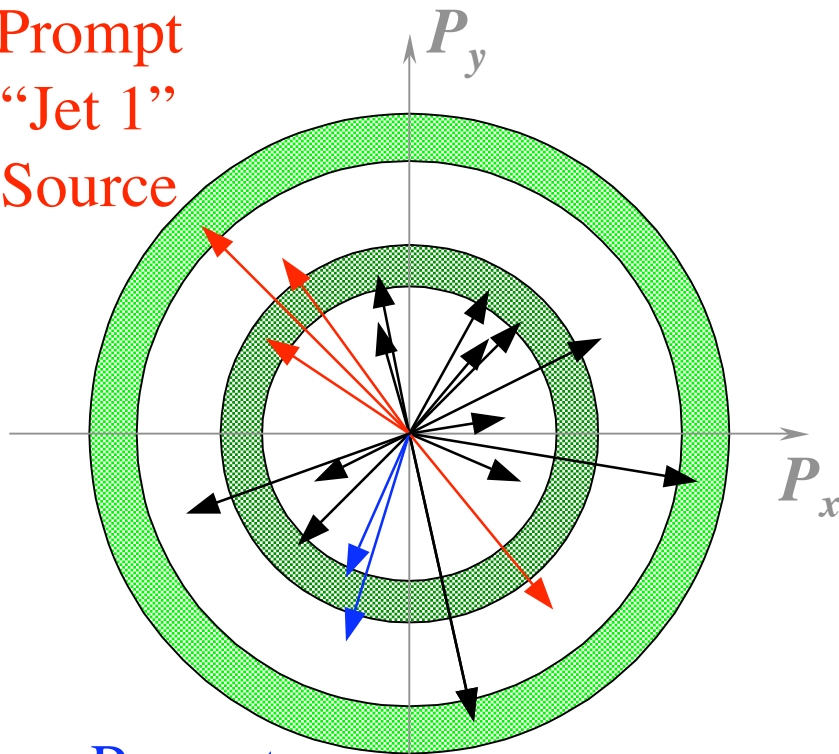

Prompt
“Jet 2”
Source

Multicollisional/
Hydrodynamic/
“Thermal”
Source

Particles A
from high- p_T
“Trigger” bin

Particles B
from low- p_T
“Partner” bin

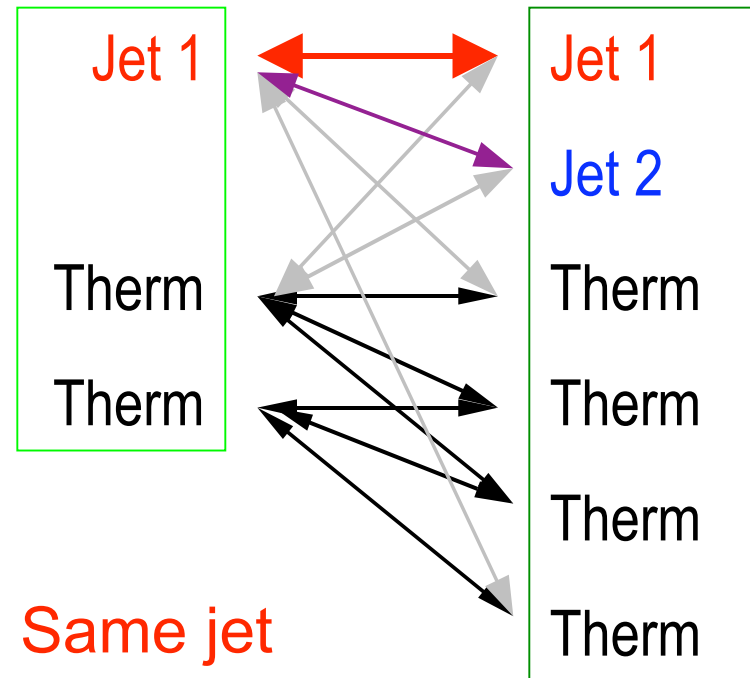

Same jet
Unrelated jets
Jet-Thermal
Thermal-Thermal

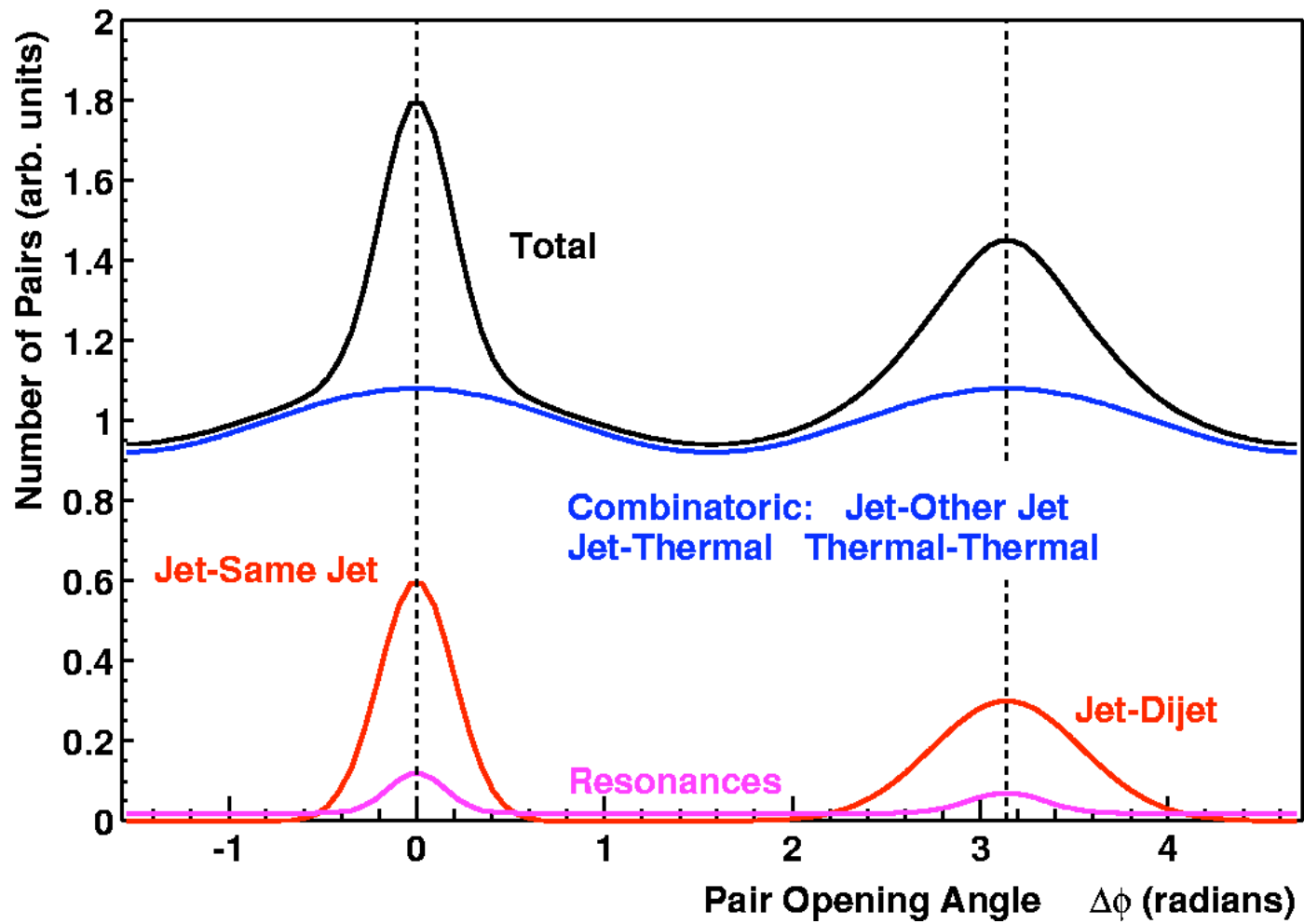

Away-side Disappearance

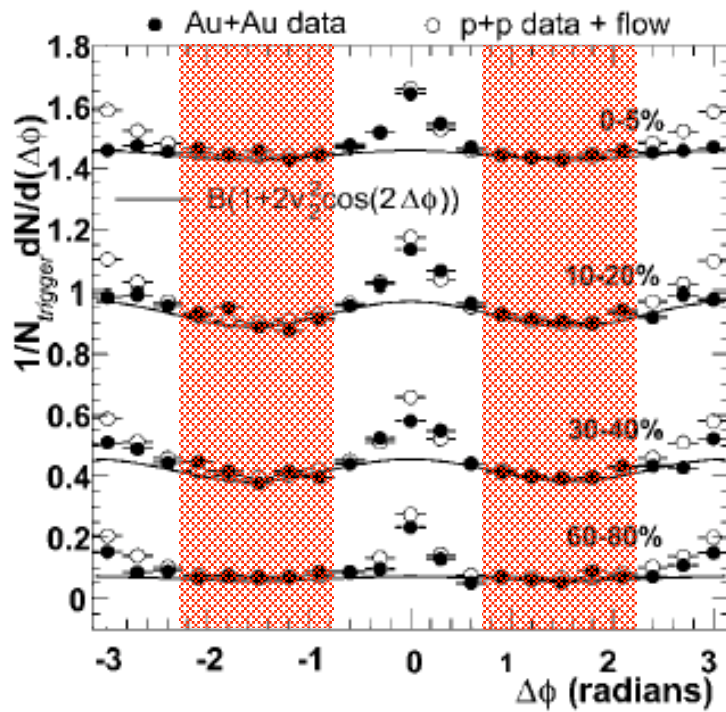

STAR PRL 90, 082302 (2003)

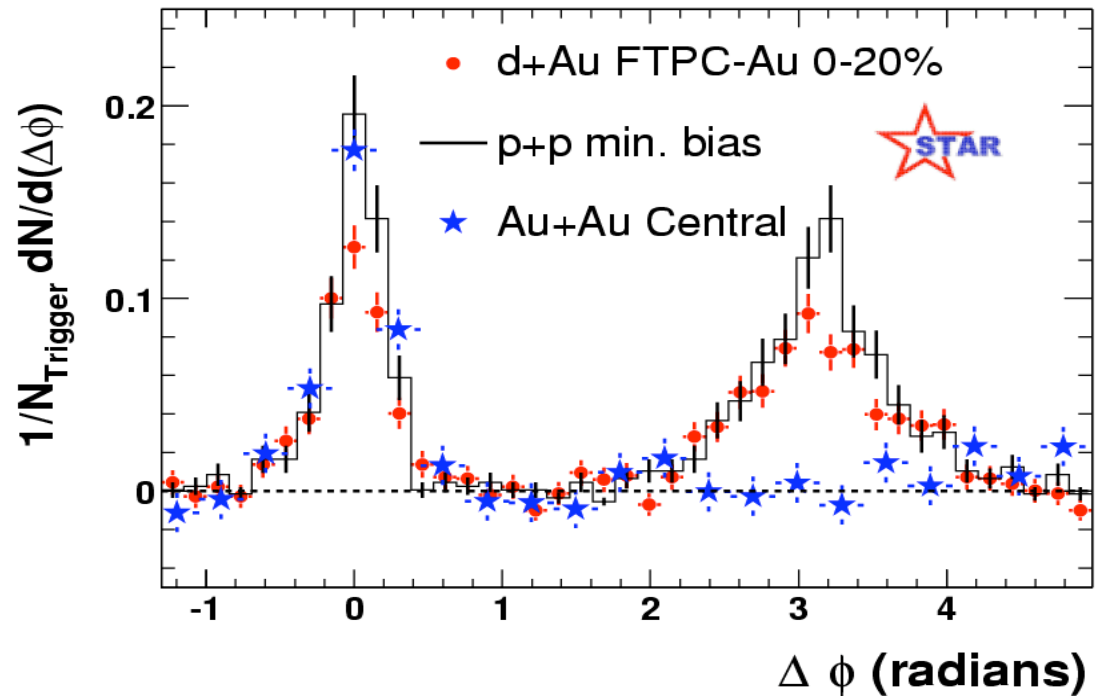
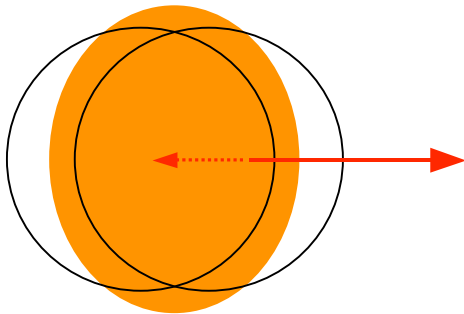

STAR PRL 91, 072304 (2003)

Away-Side Broadening

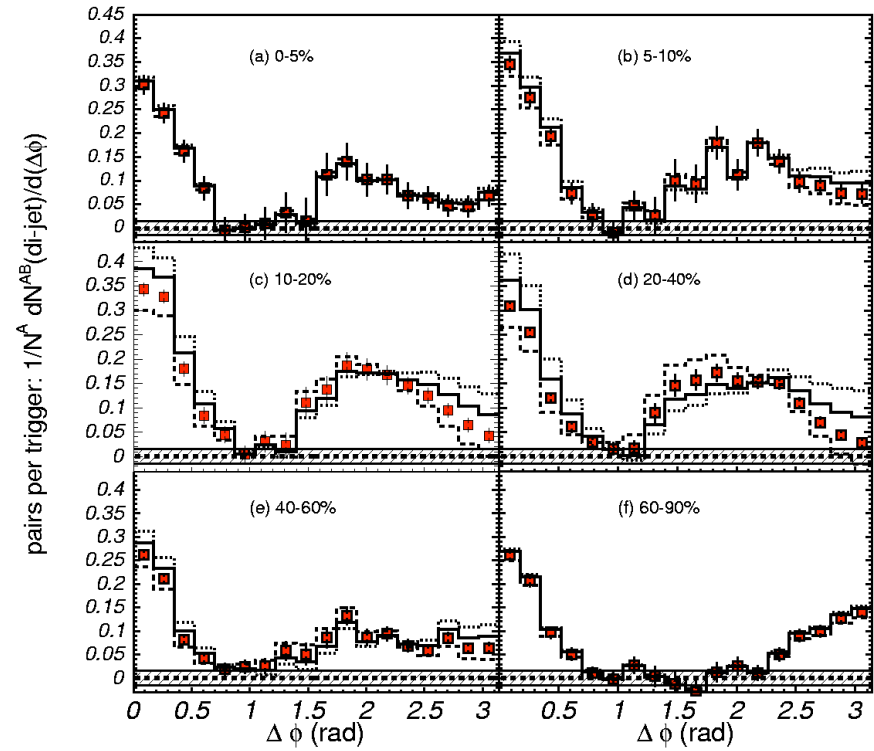
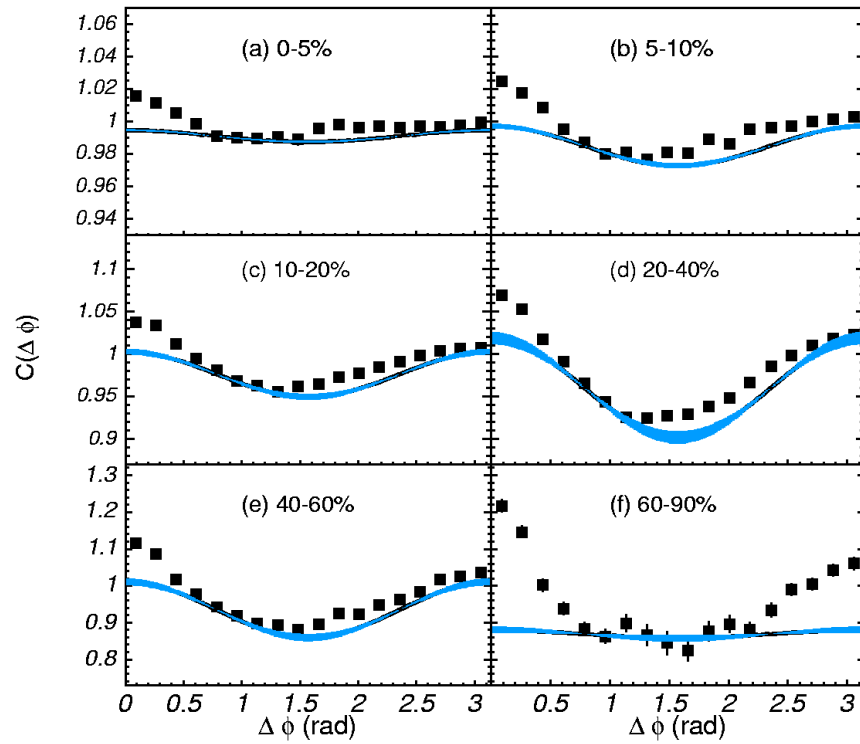

PHENIX nucl-ex/0507004 submitted to PRL

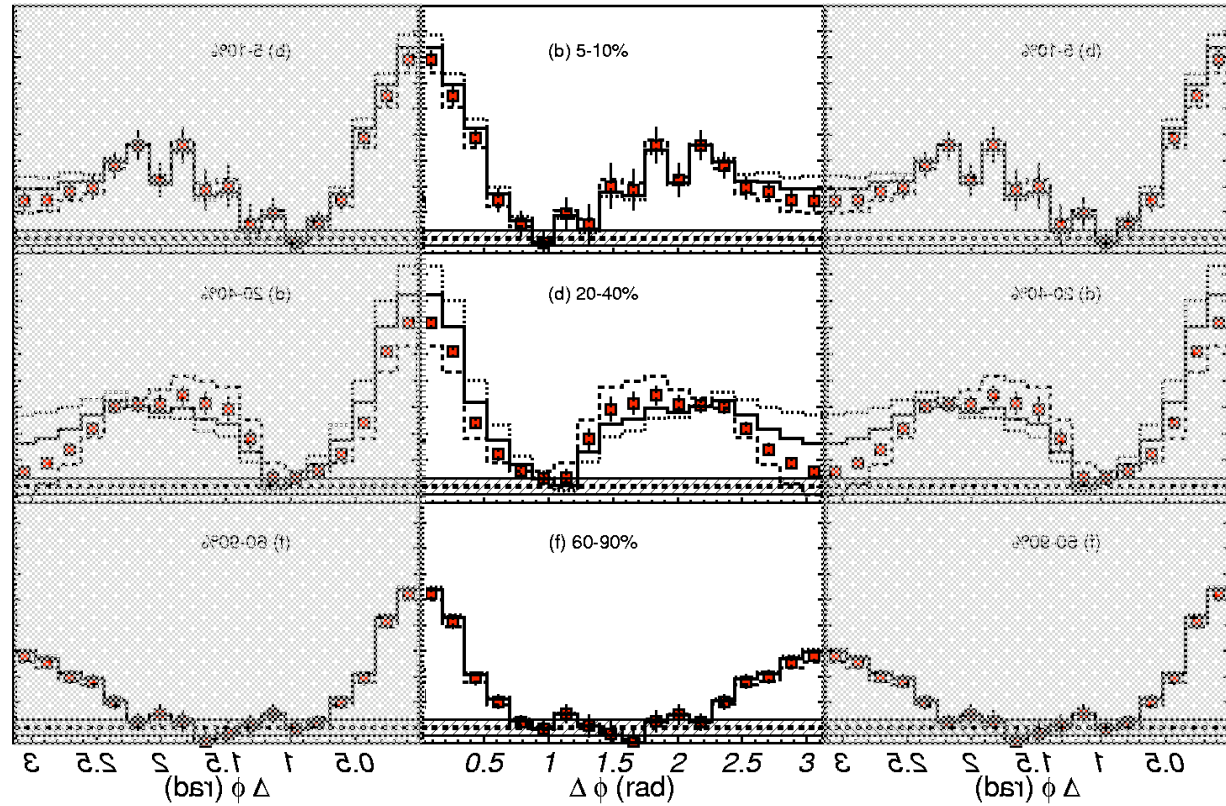

Near-side
peak

Away-side
plateau (dip?)

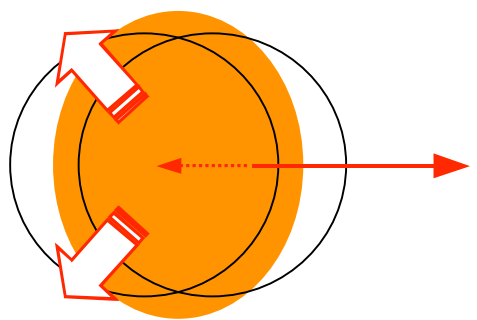
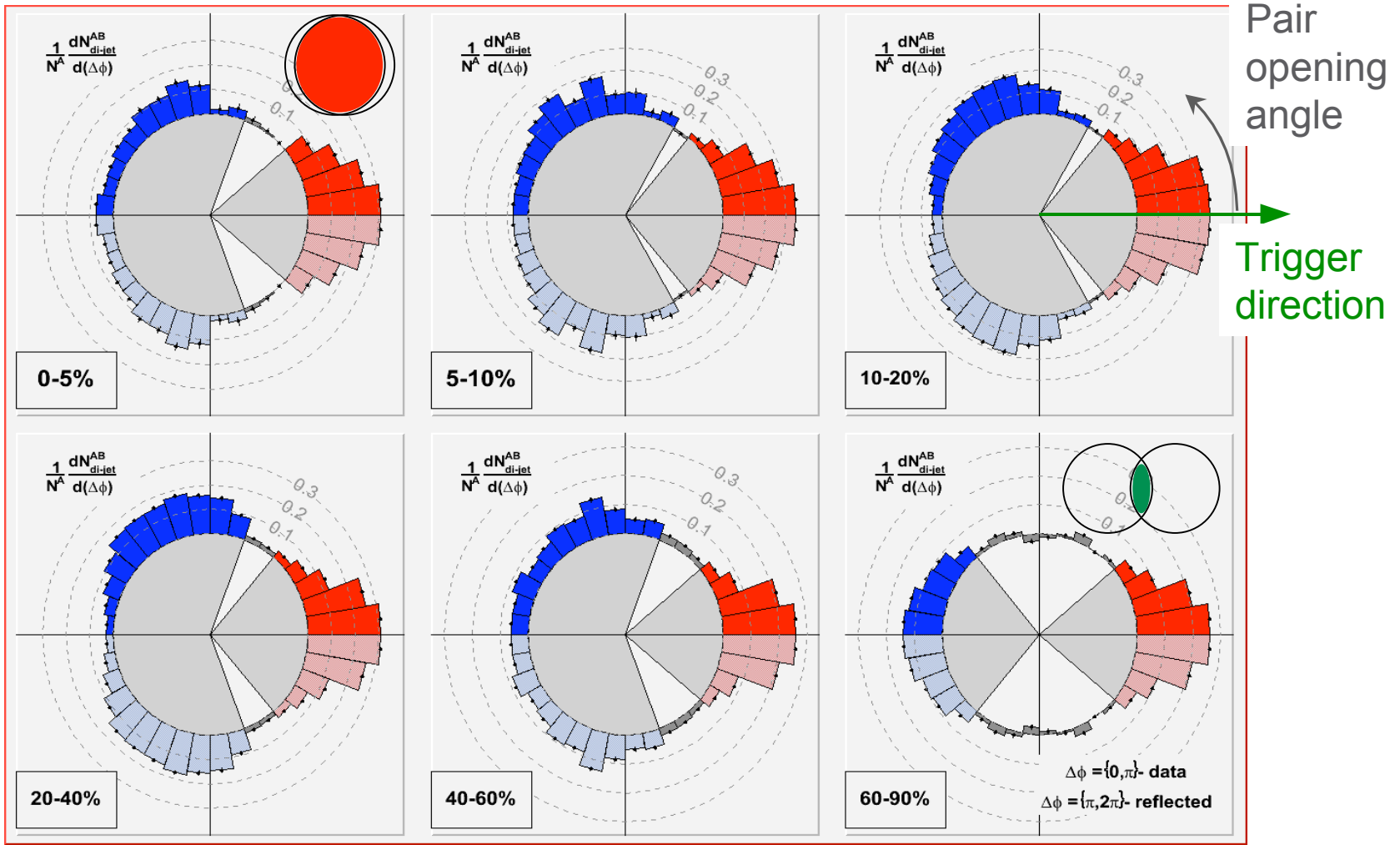

Suggestive of...

Cherenkov cones?
Mach cones?

Away-side Reappearance

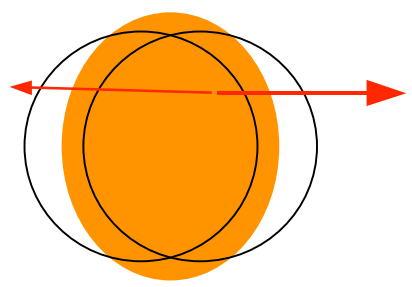
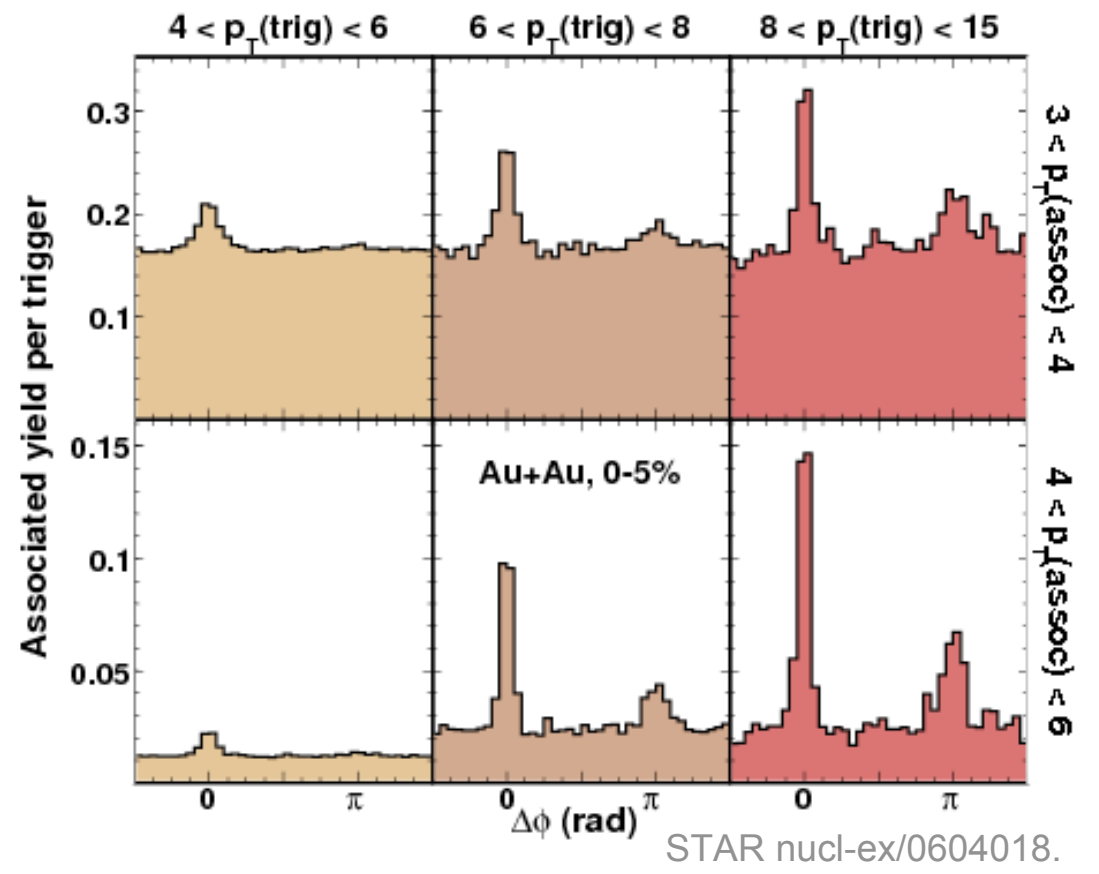
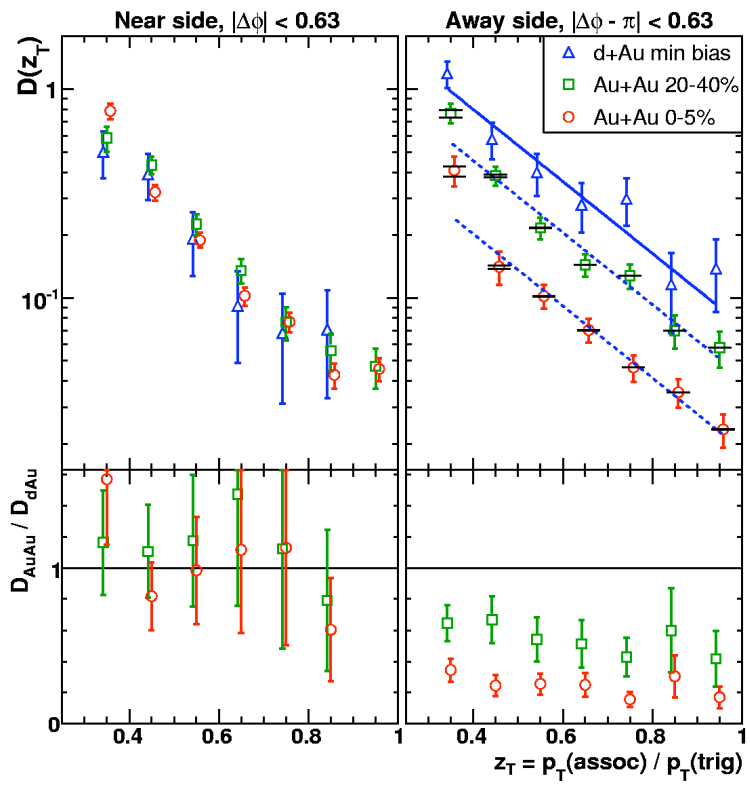

Heads and Shoulders

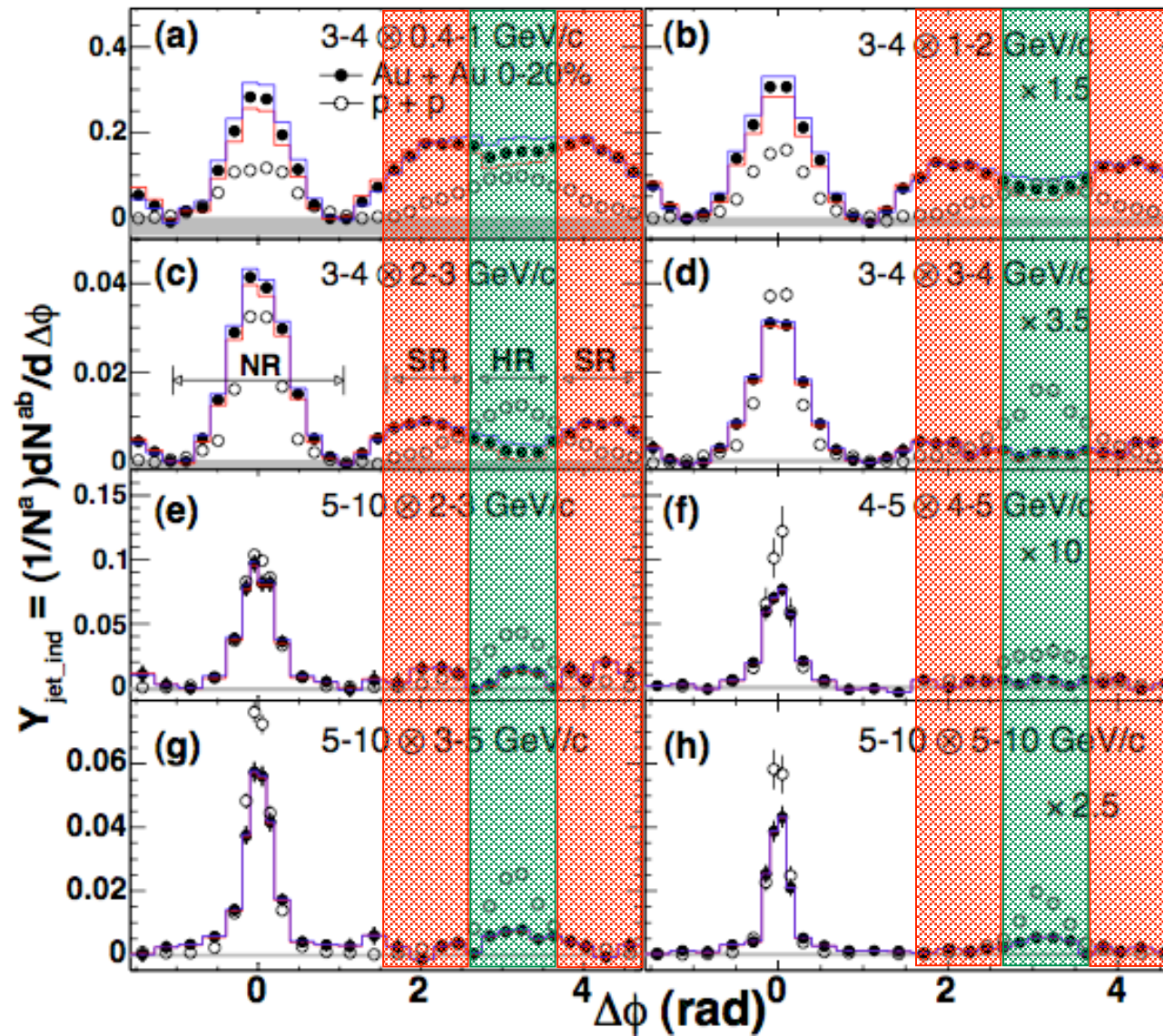

3-Particle Azimuthal Correlations

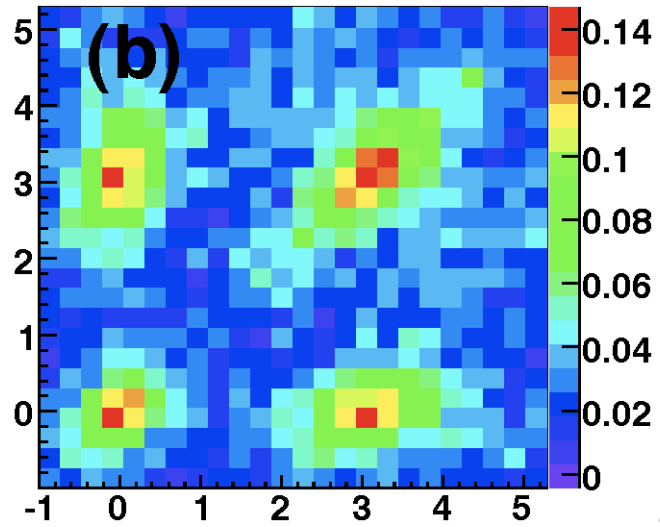
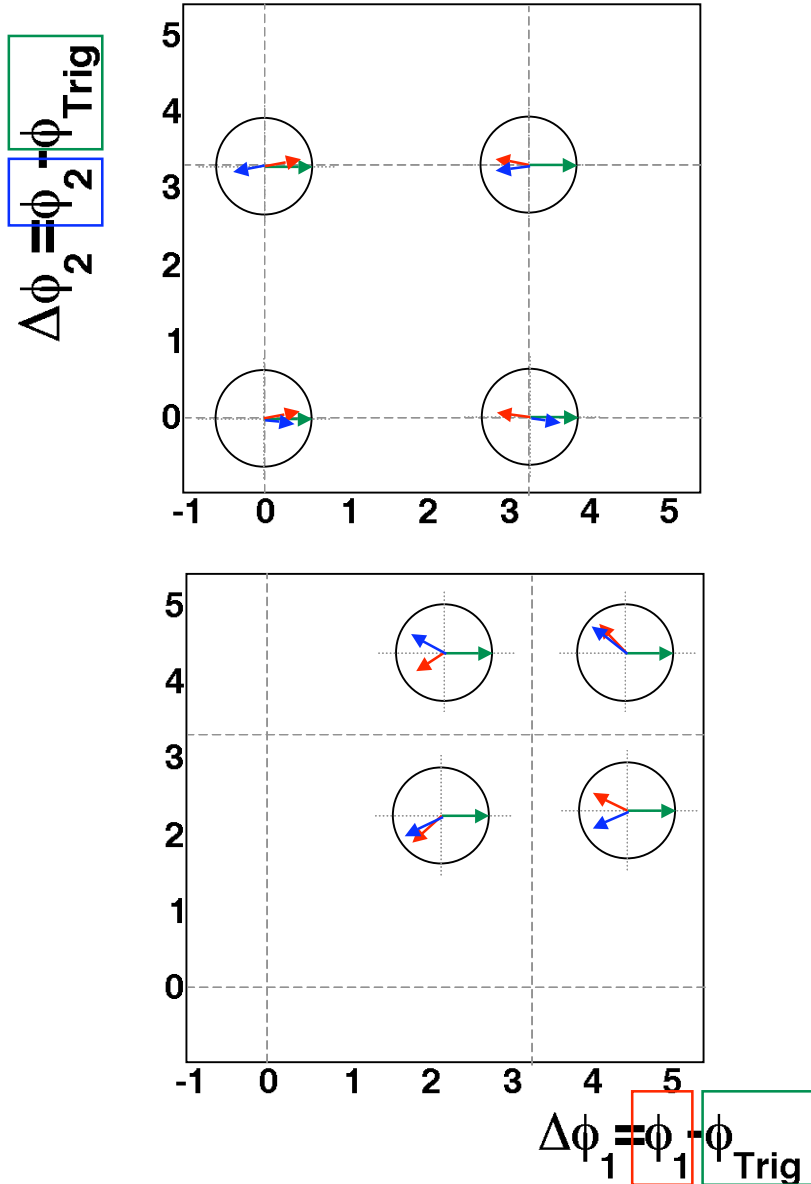

d+Au

STAR
arXiv:0806.0622

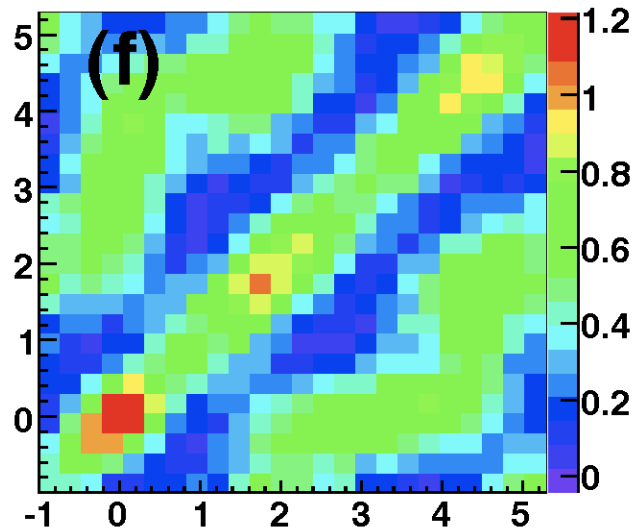

Au+Au

Jets in Azimuthal vs Polar angle

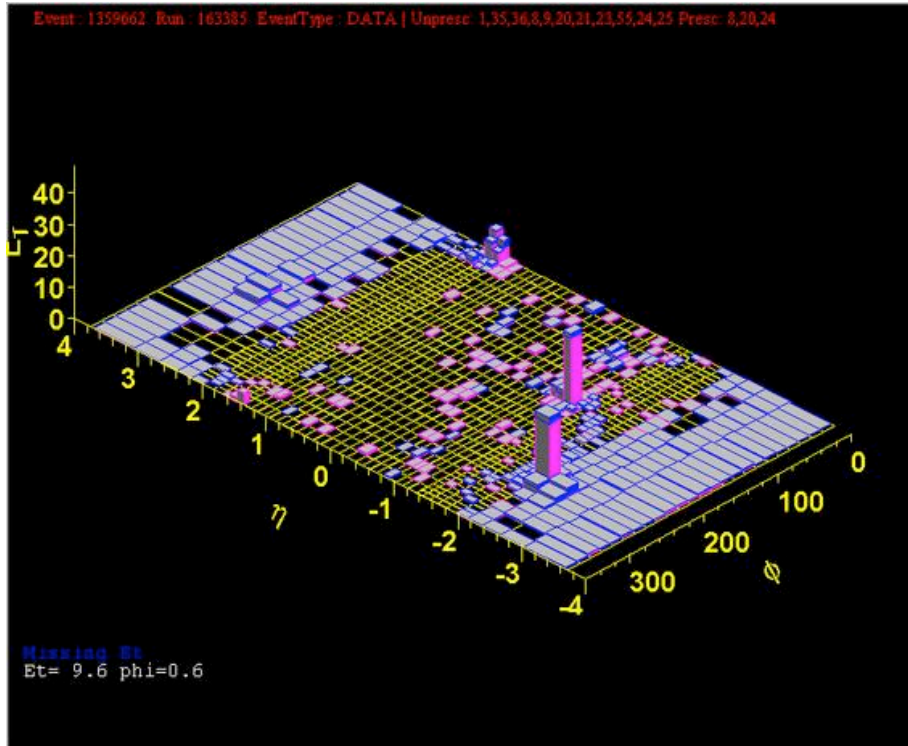

Energy

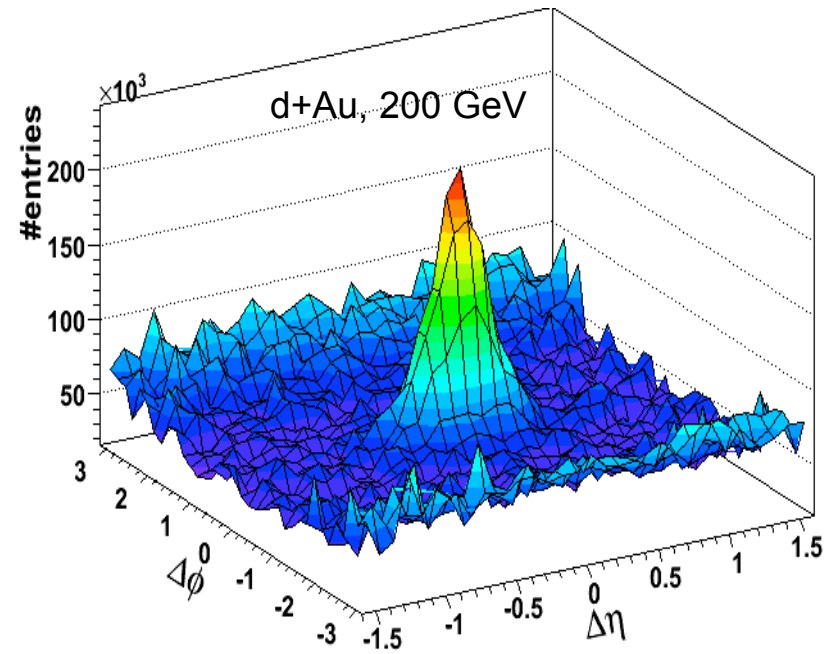

Correlated Pairs

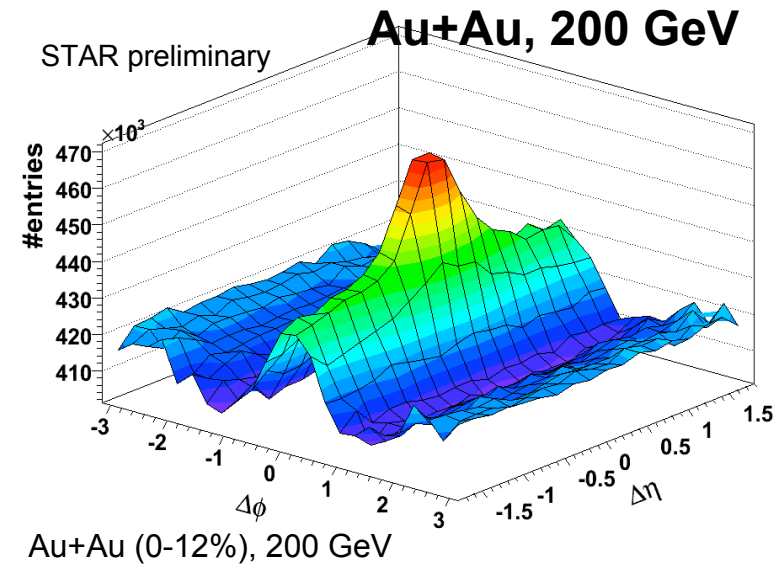
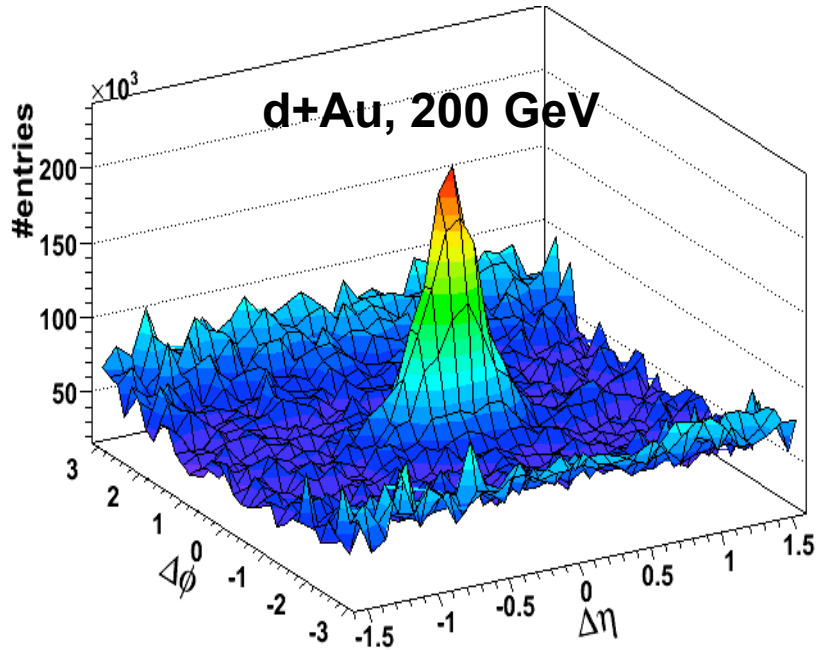

J. Putschke (STAR), QM2006

$$p_T^{\text{trig}} = 3-4 \text{ GeV}/c, 2 \text{ GeV}/c < p_T^{\text{assoc}} < p_T^{\text{trig}}$$

Near-Side "Ridge"

$$p_T^{\text{trig}} = 4-6 \text{ GeV}/c, 2 \text{ GeV}/c < p_T^{\text{assoc}} < p_T^{\text{trig}}$$

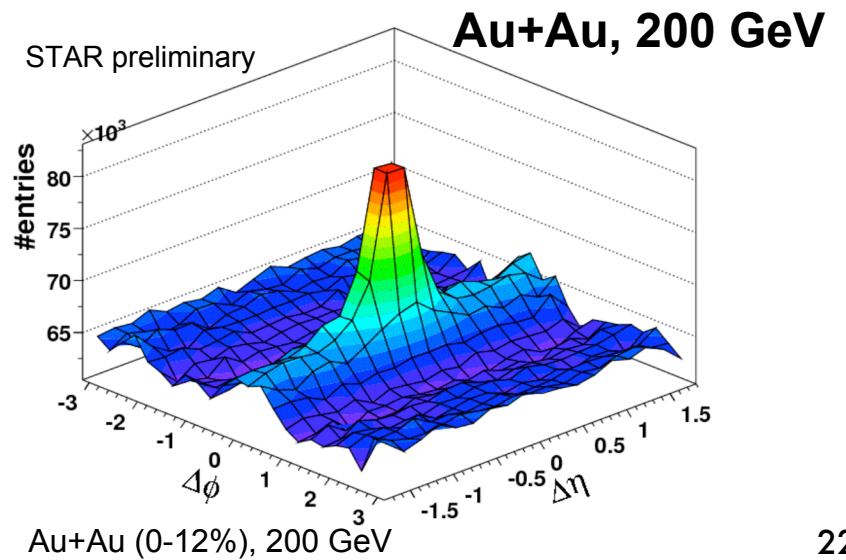

Theoretical Free-For-All

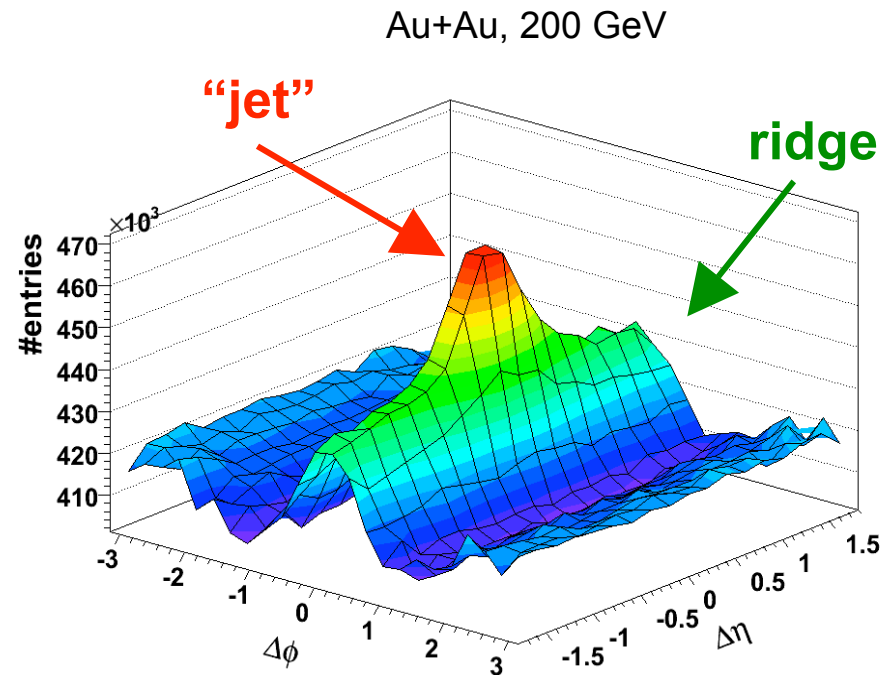

What is the ridge?

1) Medium heating and parton recombination

Chiu & Hwa PRC 72 (2005) 034903

2) Radial flow + high- p_T trigger particle

Shuryak, Phys.Rev.C76 (2007) 047901

Voloshin, nucl-th/0312065 NPA 749, (2005) 287

3) Parton radiation and its coupling to the longitudinal flow

Armesto, Salgado, Wiedemann, PRL 93 (2004) 242301

4) Momentum broadening in anisotropic QGP

Romatschke, PRC 75 (2007) 014901

5) Longitudinal broadening of quenched jets in turbulent color fields

Majumder, Mueller, Bass, PRL 99 (2007) 042301

6) Momentum kick imparted on partons in medium

Wong, PRC PRC 76 (2007) 054908

Summary

We have seen:

Singles -- Suppression /“Quenching”

Pairs in $\Delta\phi$ -- Away-side disappearance (mid-pT)

Away-side broadening/shoulders (mid-low pT)

Away-side reappearance (high pT)

Triplets in $\Delta\phi$ -- Conical emission

Pairs in $\Delta\phi$ vs $\Delta\eta$ -- Near-side “ridge”

Not to mention:

Flavor/baryon-meson separation

Jets vs reaction-plane geometry

Heavy flavor/quarkonia suppression

Direct photon -- jet correlations

Great theoretical activity (chaos?):

Crisis -> Opportunity?

RESULTS FROM THE RELATIVISTIC HEAVY ION COLLIDER

Berndt Müller

*Department of Physics, Duke University, Durham, North Carolina 27708;
email: muller@phy.duke.edu*

James L. Nagle

*Department of Physics, University of Colorado, Boulder, Colorado 80309;
email: jamie.nagle@colorado.edu*

Key Words quantum chromodynamics (QCD), quark matter, quark-gluon plasma, deconfinement, chiral symmetry restoration

■ **Abstract** This review describes the current status of the heavy ion research program at the Relativistic Heavy Ion Collider (RHIC). The new suite of experiments and the collider energies have opened up new probes of the medium created in the collisions. Our review focuses on the experimental discoveries to date at RHIC and their interpretation in light of the field's present theoretical understanding of the dynamics of relativistic heavy ion collisions and of the structure of strongly interacting matter at high energy density.